

# LEON

---

## Instruction Book

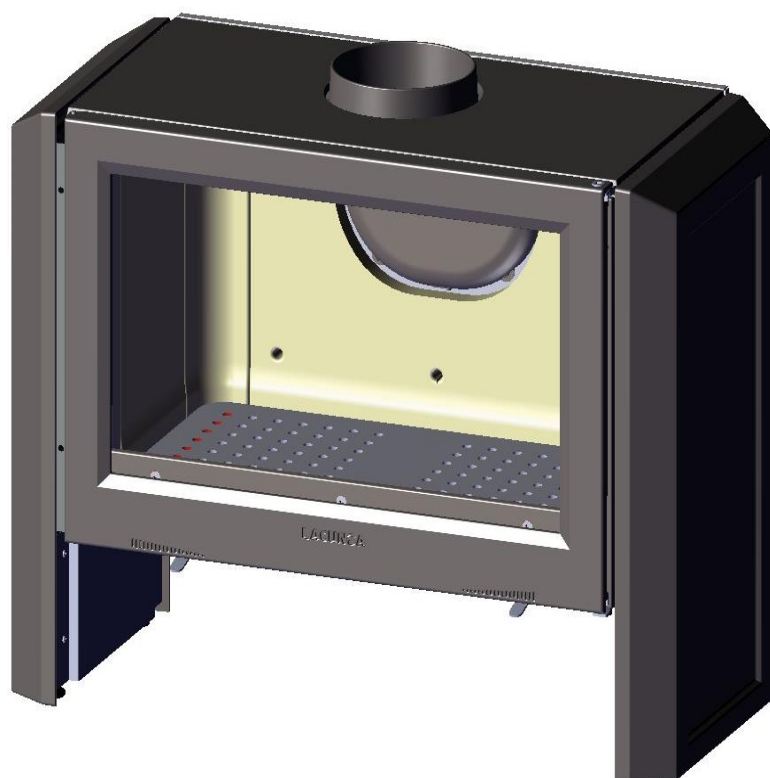

Lacunza congratulates you on your choice.  
Certified under ISO 9001, Lacunza guarantees the quality of its appliances and undertakes to meet the needs of its customers.

Confident of the know-how afforded by more than 50 years' experience, Lacunza uses advanced technologies in the design and manufacture of its entire range of appliances. This document will help you install and use your appliance in optimum conditions for your comfort and safety.

## CONTENTS

1. PRESENTATION OF THE APPLIANCE .....	3
1.1. General characteristics.....	3
2. INSTRUCTIONS FOR THE INSTALLER.....	5
2.1. Warning to installers .....	5
2.2. Room for installation.....	5
2.2.1. Ventilation of the room.....	5
2.2.2. Location of the appliance in the room .....	6
2.3. Installation of the appliance.....	6
2.3.1. Floor.....	6
2.3.2. Safety distances.....	6
2.3.3. Checks before lighting for the first time .....	6
2.3.4. Height adjustment and levelling the appliance.....	6
2.3.5. Connection to the flue.....	6
2.4. Chimney flue.....	7
2.4.1. Type of flue.....	7
2.4.2. Chimney crown.....	8
3. INSTRUCTIONS OF USE .....	10
3.1. Fuel.....	10
3.2. Description of the parts of the appliance .....	11
3.2.1. Operating components .....	11
3.3. Lighting.....	12
3.4. Safety.....	13
3.5. Loading fuel .....	13
3.6. Operation .....	13
3.7. Removing ash.....	14
3.8. Deflectors. Flapper valve .....	14
4. MAINTENANCE AND IMPORTANT ADVICE.....	16
4.1. Maintenance of the appliance.....	16
4.1.1. Firebox .....	16
4.1.2. Inside the appliance .....	16
4.1.3. Flue socket .....	16



4.1.4. Painted sheet-steel-cast-iron parts.....16

4.1.5. Firebox glass.....16

4.2. Maintenance of the chimney flue.....16

4.3. Important advice.....16

5. TROUBLESHOOTING.....17

6. BASIC BREAKDOWNS ..... 18

7. DECLARATION OF PERFORMANCE.....20

8. CE MARK..... 22

## 1. PRESENTATION OF THE APPLIANCE

For optimum operation of the appliance, we advise you to read this manual carefully before switching on the appliance for the first time. In case of problems or concerns, we urge you to contact your dealer, who will cooperate with you.

In order to improve the product, the manufacturer reserves the right to make changes without notice by updating this document.

This appliance is designed to burn wood in absolutely safe conditions.

**WARNING:** Faulty installation may have serious consequences.

Installation and all necessary regular maintenance operations must be performed by an authorized installer in full accordance with the specifications set out in the legislation applicable in each country and this instruction book.

### 1.1. General characteristics

	Unit	LEON
Nominal Heat Output (N.H.O.) to atmosphere	kW	20.4
Efficiency at N.H.O.	%	78.2
CO emission at 13% O <sub>2</sub> at N.H.O.	%	0.2
Gas mass flow at N.H.O.	g/s	12
Gas temperature downstream of flue socket at N.H.O.	°C	413
Optimum flue draught	Pa	12
Wood consumption (beech) at N.H.O.	Kg/h	6.1
Dimensions of the firebox		
Width	mm	740
Depth	mm	373
Useful height	mm	430
Dimensions of the logs	cm	30
Volume heated (45w/m <sup>3</sup> ) at N.H.O.	m <sup>3</sup>	433
Log load frequency	h	1
Capacity of the ashpit	L	8.8
Weight	kg	260
Flue socket diameter	mm	200

**Note:** The values indicated in the above table are based on tests performed in accordance with UNE-EN 13240 with logs with no more than 18% humidity and pressure conditions as indicated in each case.

**Warning:** this appliance is designed and prepared to work with the types of fuel, degree of humidity of the fuel, fuel loads, fuel load frequencies, flue draught and system of installation indicated in this Instruction Book. Failure to respect these conditions may lead to problems with the appliance (deterioration, shorter useful life, etc.) which are not covered by the Lacunza warranty.

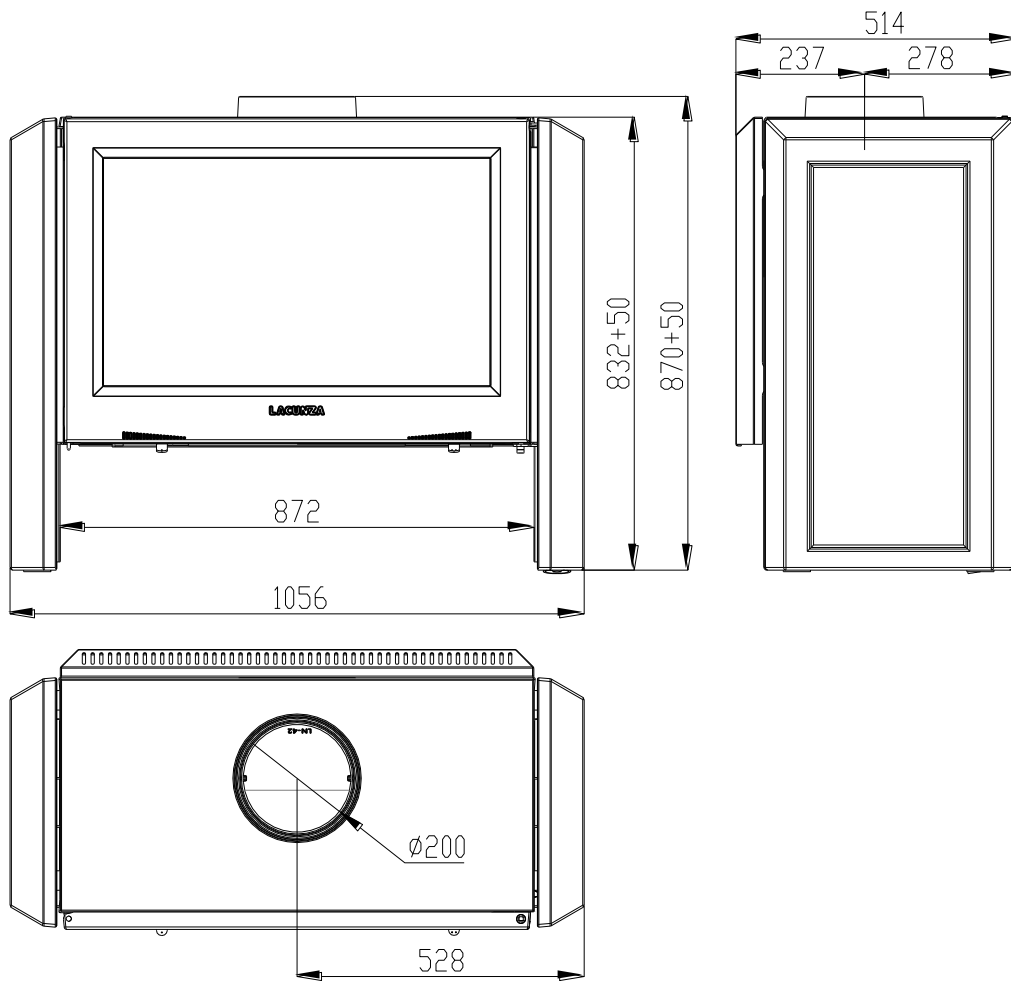

Figure No.1 - Dimensions of the LEON appliance in mm

## 2. INSTRUCTIONS FOR THE INSTALLER

### 2.1. Warning to installers

All local and national regulations, including all those referring to national and European standards, must be observed when installing the appliance.

Installation of the appliance must be performed by an authorised installer.

An incorrectly installed appliance may lead to serious incidents (fires, creation of harmful gases, deterioration of nearby fixtures, etc.).

Lacunza's liability is limited to the supply of the material and does not include installation of the appliance.

### 2.2. Room for installation

#### 2.2.1. Ventilation of the room

The appliance needs to consume oxygen (air) in order to work properly. Ensure a suitable air supply in the room in which the appliance is fitted. This quantity of oxygen is additional to the oxygen that we need in order to breathe (air renewal).

In order to ensure the high quality of the air you breathe and to avoid potential accidents resulting from high concentrations of the gases produced by combustion (mainly carbon dioxide and carbon monoxide), it is absolutely crucial to ensure the suitable renewal of the air in the room in which the appliance is fitted.

the room must always have at least two permanent grilles or openings to the exterior in order to renew the air (one for intake and the other for extraction).

For the installation of its appliances, Lacunza recommends an additional section for these openings. One of these two grilles must be situated high up in the room (at less than 30 cm from the ceiling)

and the other one low down (at less than 30 cm from the floor). Both grilles must open outdoors in order to renew the air in the room with fresh air.

The minimum section that each of these grilles must have depends on the nominal output of the appliance in accordance with the following table:

Output of the appliance (kW)	Minimum additional section of each of the grilles (cm <sup>2</sup> )
$P \leq 10\text{kW}$	70
$10 < P \leq 15$	90
$15 < P \leq 20$	120
$20 < P \leq 25$	150
$25 < P \leq 30$	180
$30 < P \leq 35$	210
$P > 35$	240

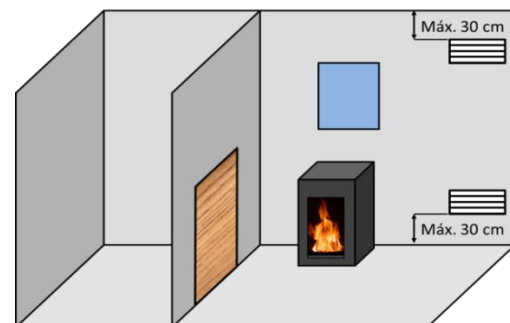

Figure No.2 - Guideline indications for ventilation grilles

The appliance must always be used with the door(s) closed.

In rooms equipped with Controlled Mechanical Ventilation, the system extracts and renews the ambient air; in such cases, the room is at slightly low pressure and it is necessary to install a non-closable outside-air inlet with a section of at least 90 cm<sup>2</sup>.

### 2.2.2. Location of the appliance in the room

Choose a location in the room which favours good hot-air distribution by convection and radiation.

## 2.3. Installation of the appliance

### 2.3.1. Floor

Make sure that the base can withstand the total constructed weight of the appliance and its casing.

When the floor surface (base) is combustible, fit suitable insulation.

### 2.3.2. Safety distances

Be sure to respect the appliance installation distances from **combustible materials**. Looking at the appliance head-on:

	Distance to combustible materials (mm)
From the right-hand side	400
From the left-hand side	400
From the rear	500
From the front	1000

Bear in mind that it may even be necessary to protect non-combustible material in order to prevent breakage, deformation, etc., as a result of overheating if the non-combustible material is not designed to withstand high temperatures.

### 2.3.3. Checks before lighting for the first time

- Make sure that the glass is not broken or damaged.
- Make sure that the flueway is not obstructed with packing or loose parts.
- Make sure that the airtight joints on the flue circuit are in perfect condition.

- Make sure that the doors close properly.
- Make sure that all moving parts are fitted in place.

### 2.3.4. Height adjustment and levelling the appliance

The appliance must be perfectly level, horizontally and vertically, both at the front and on the sides (use a spirit level).

The appliance has adjustable legs with which to adjust its height.

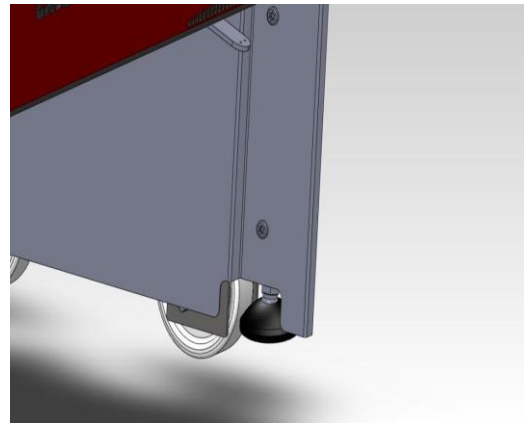

*Figure No.3 - Legs with which to height-adjust the appliance*

### 2.3.5. Connection to the flue

The appliance must be connected to the chimney flue using special piping designed to resist the products of combustion (e.g. stainless steel, enamelled steel, etc.).

To connect the flue to the socket flange, insert the piping inside the flange and seal the joint with fire sealant or fire cement to make it completely airtight.

The installer must ensure that the pipe connected to the appliance is well secured and there is no chance of it coming free from its housing (e.g. as a result of dilatation due to temperature, etc.).

On this appliance, the flue socket can be fitted either on top or at the rear of the appliance.

The appliance have the flue socket on the top position, but you can change to the rear position:

- Remove the deflector
- Remove 4 screws of the flue socket and the 4 screws of the rear cover.

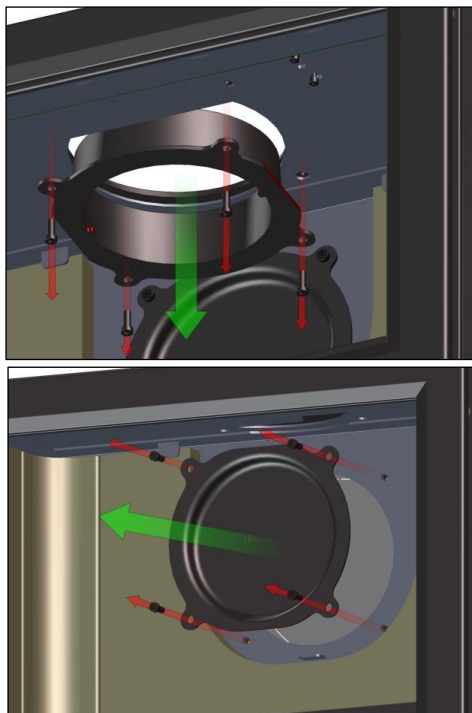

Figure No.4 - Remove the flue socket and the rear cover.

- Break off the hole on the rear sheet iron.

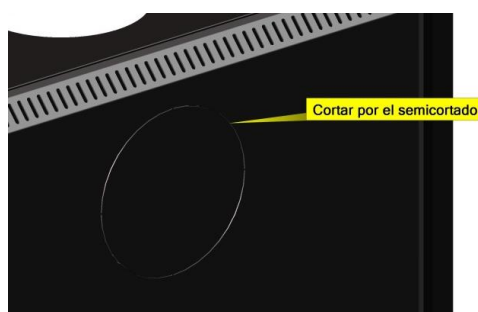

Figure No.5 - Break off the hole on the rear sheet iron.

## 2.4. Chimney flue

The chimney flue must comply with present standards on the installation of chimneys.

In rooms equipped with Controlled Mechanical Ventilation, the ventilation outlet must never be connected to the flue.

The appliance must always have its own chimney flue, never sharing a chimney flue with another appliance.

### 2.4.1. Type of flue

The flue must be made of special material designed to resist the products of combustion (e.g. stainless steel, enamelled steel, etc.).

Non-central-heating appliances (without back boiler) require an insulated, double-sleeve flue only on those sections that run outdoors or through cold areas. Single piping can be used inside the building, the heat of the gases serving to heat rooms, insulating only those sections where excess temperature may cause damage.

If the chimney is constructed, then it is necessary to pipe and insulate it to ensure correct updraught.

The diameter of the pipe must be the same as the diameter of the flue socket on the appliance over its entire length in order to ensure correct operation.

The flue must prevent the entry of rainwater.

The flue must be clean and airtight over its entire length.

The flue must be at least 6m tall and the chimney cap must not hinder the free release of gases.

If the flue tends to suffer from downdraught, then it is necessary to fit an effective anti-downdraught cowl, a static

cowl or a smoke extraction fan, or reshape the chimney.

Never make 90° bends, due to the great loss of draught they cause, and reduce 45° bends down to an absolute minimum. Each 45° bend is equivalent to a 0.5m reduction in flue length. Horizontal flue sections should not be installed because they cut updraught a great deal.

If the flue draws at more than 20 Pa on 12Pa appliances, then an effective damper must be fitted on the flueway. This damper must be visible and accessible.

The chimney flue must not rest on the appliance.

Bear in mind that high temperatures may be reached in the flue, meaning that it is essential that insulation be enhanced in sections in which combustible material is present (wooden beams, furniture, etc.). It may even be necessary to protect non-combustible material in order to prevent breakage, deformation, etc., as a result of overheating if the material is not designed to withstand high temperatures.

It must be possible to clean the entire flue, no sections being left inaccessible for cleaning purposes.

#### 2.4.2. Chimney crown

The upper end of the chimney must clear the roof, the roof ridge or any obstacle located on the roof by at least 1m.

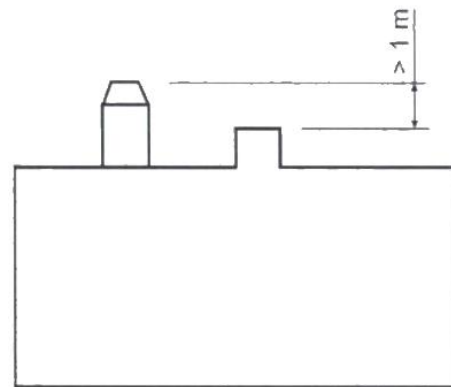
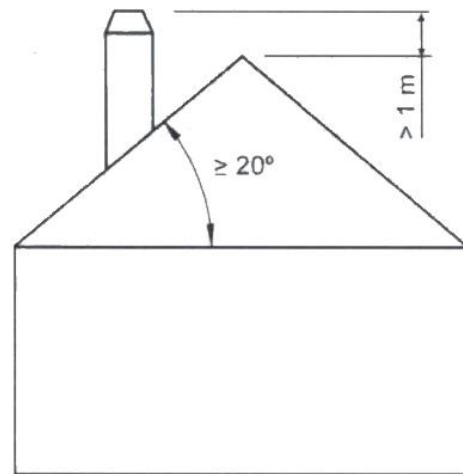
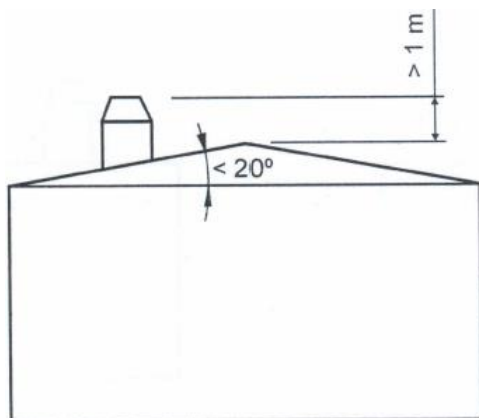
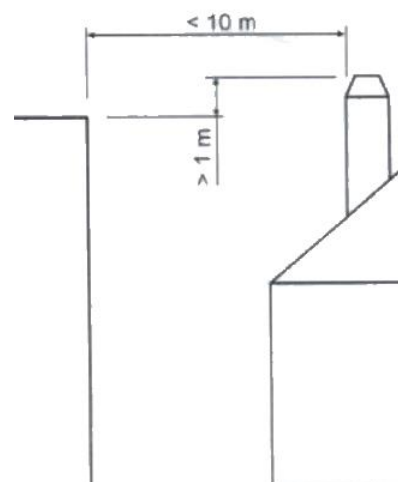

Figure No.6 - Distances between chimney crown and roof ridge

The chimney crown must clear the highest point of any neighbouring building or obstacle located within a 10m radius of the chimney outlet by more than 1m.





*Figure No.7 - Distances between the chimney crown and objects within a 10m radius*

The chimney crown must clear any neighbouring building or obstacle located within a radius of 10m to 20m from the chimney outlet.

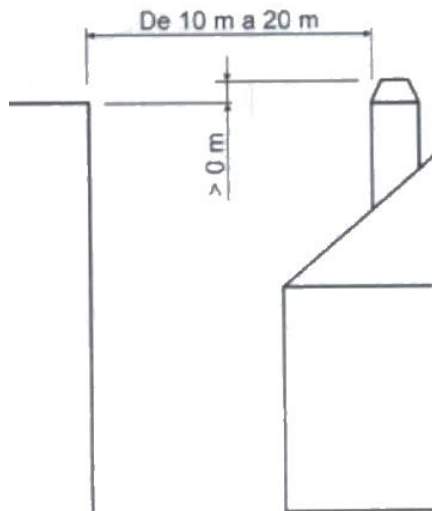

*Figure No.8 - Distances between the chimney crown and objects within a radius of between 10 and 20m*

### 3. INSTRUCTIONS OF USE

The manufacturer accepts no liability whatsoever for damage caused to parts as a result of the improper use of non-recommended fuels, modifications made to the appliance or how it is installed.  
**Only use original replacement parts.**

All local and national regulations, including those referring to national and European standards, must be observed when using the appliance.

Heat is diffused by radiation and convection via the front and exterior of the appliance.

#### 3.1. Fuel

This appliance must not be used as an incinerator. Do not use non-recommended fuels.

- Use dry logs (max. 16% humidity), cut at least 2 years ago, clean of resin and stored in a sheltered, ventilated place.
- Use hard woods with high calorie values and good ember production.
- Large logs should be cut to useable lengths before being stored. The logs should have a maximum diameter of 150mm.
- Finely-chopped wood produces greater heat output, but also burns more quickly.

#### Optimum fuels:

- Beech.

#### Other fuels:

- Oak, chestnut, ash, maple, birch, elm, etc.
- Pine and eucalyptus logs are low density and produce very long flames, and may cause the parts of the

appliance to wear out more quickly than normal.

- Resinous wood may mean that the appliance and the flue need to be cleaned more often.

#### Non-permitted fuels:

- All types of coal and liquid fuel.
- “Green wood”. Green or damp wood reduces the performance of the appliance and leads to soot and tar build-up on the inner walls of the flue, obstructing it.
- “Recovered wood”. The burning of treated woods (railway sleepers, telegraph posts, plywood, fibreboard, pallets, etc.) quickly blocks the system (soot and tar build-up), harms the environment (pollution, smells) and may lead to deformation of the firebox due to overheating.
- All materials which are not wood (plastic, spray cans, etc.).

Green and reprocessed wood may cause chimney fires.

The graph below shows how the humidity of firewood affects its heat output:

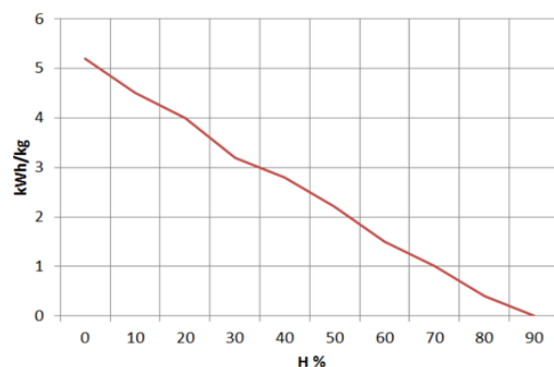

Figure No.9 - Relationship between firewood humidity and heat output.

## 3.2. Description of the parts of the appliance

### 3.2.1. Operating components

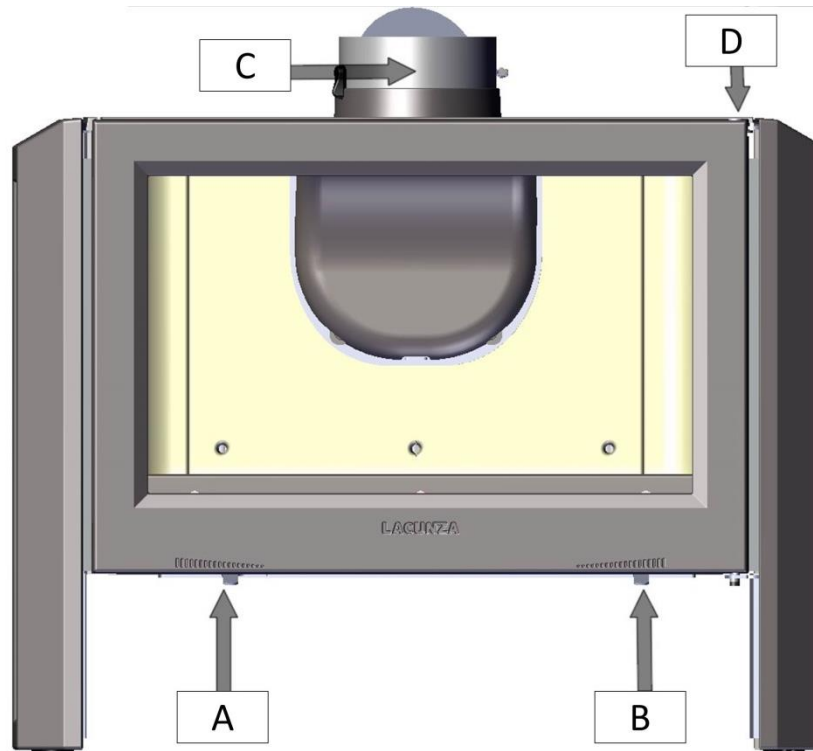

Figure No.10 - Operating components on the appliance

- A: Primary air intake
  - A1 open (right)
  - A2 closed (left)
- B: Secondary air intake
  - B1 open (right)
  - B2 closed (left)
- B: Double-combustion air intake
  - B1 open (right)
  - B2 closed (left)
- C: Draught damper flapper valve
- D: Firebox door handle

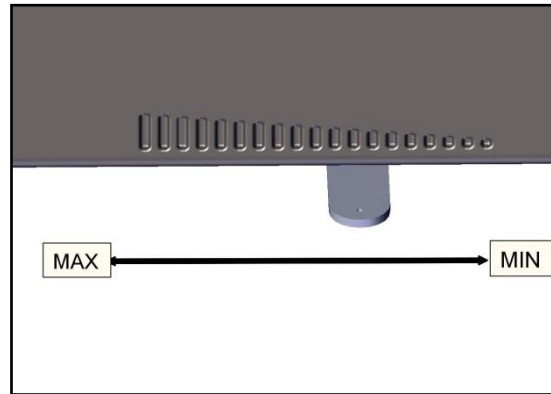

Figure No.11 - Air intake

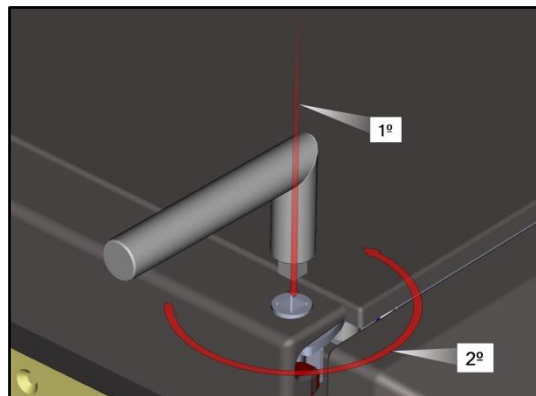

Figure No.12 - Firebox door handle

### 3.3. Lighting

Use of the appliance in warm weather (warm days, early hours of the afternoon on sunny days) may lead to lighting and updraught problems.

Certain weather conditions, such as fog, ice, humidity entering the flue, etc., may hinder sufficient updraught in the flue and lead to suffocation.

Proceed as follows in order to light the appliance satisfactorily:

- Open the firebox door and open all the firebox air-intake inlets to the full.
- Place paper or a firelighter and some wood chips in the firebox.

- Light the paper or firelighter.
- Leave the door slightly ajar, the width of two or three fingers, for about 15 minutes until the glass warms up.
- The first time the appliance is lit, the fire should be gentle to allow the parts of the appliance to dilate and dry.

**Important:** The first time it is lit up, the appliance may give off smoke and strange smells. This is not a cause for concern. Open an outdoor window to ventilate the room during the first few hours of operation.

If you notice water around the appliance, this is produced by the condensation of the moisture in the wood on lighting the fire. This condensation will no longer appear when the appliance has been lit three or four times and has adapted to its flue. If it does not disappear, then check the flue draught (length and diameter of the flue, flue insulation, airtightness) and the humidity of the wood used.

### 3.4. Safety

Do not store combustible materials beneath the appliance.

### 3.5. Loading fuel

In order to load firewood, open the firebox door gently, preventing the sudden entry of air to the firebox so that smoke does not enter the room that the appliance is installed in.

Perform this operation with the glove to prevent burns to the hands.

The maximum load height is 2 logs with diameters of approx. 10 cm.

The minimum interval between loads for nominal heat output is 60 minutes.

Always load with the nominal amount (see table in section 1.1).

For minimum burning (e.g. at night), use thicker logs.

When the firebox is loaded, close the door.

Be careful when placing logs in the firebox on appliances with vermiculite interiors. Vermiculite is a fragile material and may crack if knocked.

### 3.6. Operation

The appliance should be operated with the door closed and the direct draught rod closed.

For safety reasons, never close all the appliance's combustion-air intakes.

#### Primary-air intake

By opening this inlet, air enters the firebox via the firebox grille.

#### Secondary-air intake

By opening this inlet, air enters the firebox via the top of the firebox door.

**IMPORTANT:** Keeping the secondary-air intake open helps keep the door glass cleaner for longer.

#### Double-combustion air intake

By opening this inlet, air enters the combustion flame, making for more efficient and less polluting combustion because post-combustion takes place, burning the particles which were not burned in the first combustion. This increases the performance of the appliance and reduces emissions.

On Leon models, the double-combustion air intake is the same as the secondary-air intake (both air intakes are controlled through the same inlet at the same time).

**IMPORTANT:** The appliance is exposed to extreme changes in temperature and may, as a result, make noises when in operation. These noises are a natural result of expansion/contraction of the parts which make up the appliance. Do not be alarmed by noises of this kind.

In order to obtain maximum output, open all the air intakes to the firebox and in order to obtain minimum output, tend towards closing them. For normal use, we recommend you close the Primary Intake and leave the Secondary and Double Combustion Intakes open.

### 3.7. Removing ash

Following sustained use of the appliance, it is necessary to remove the ash from the firebox. Remove the ashpit box when cold or using something to prevent yourself from getting burned (glove).

Never throw hot embers into the rubbish.

Access the ashpit by opening the door on the appliance.

### 3.8. Deflectors. Flapper valve

The appliance has an updraught-regulating flapper valve on the flue socket. This can be used to modify the section through which the gases pass and, consequently, control the updraught.

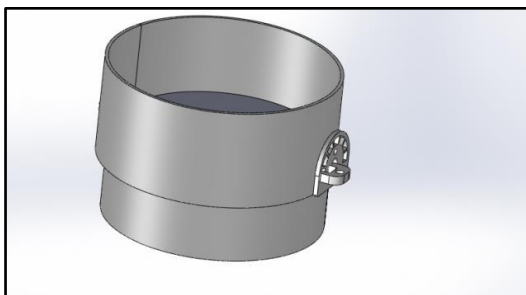

Figure No.13 - Flapper valve closed

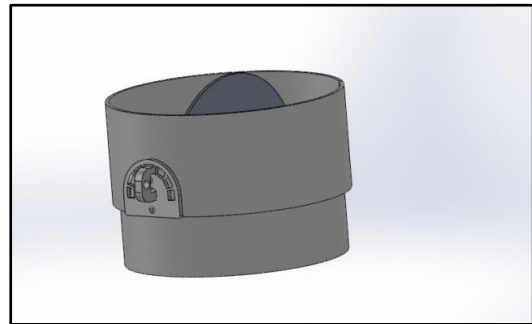
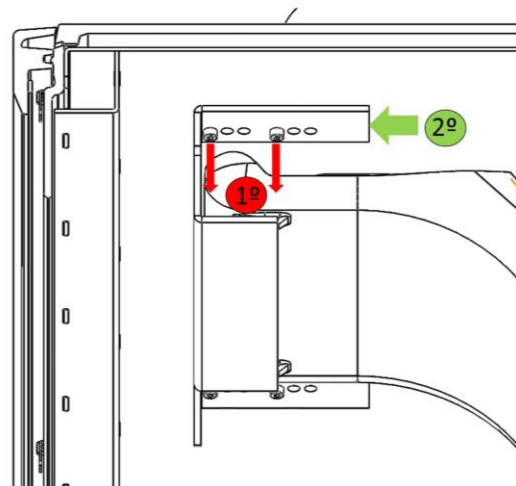

Figure No.14 - Flapper valve opened

The appliance has 1 deflector.

The deflector can be dismantled (the deflector has 3 positions in order to adapt it better to the flue draught - provided there is minimum updraught). Position 1, more closed (greater resistance to smoke evacuation, greater retention and, therefore, greater efficiency). Position 3, more open (to be used when there are smoke downdraught problems caused by insufficient updraught).

You can see how it is fitted and regulated in the following pictures.



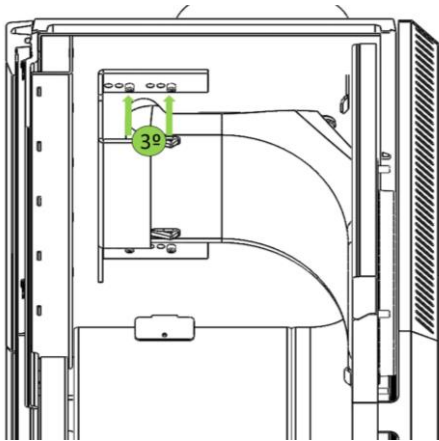

## **4. MAINTENANCE AND IMPORTANT ADVICE**

### **4.1. Maintenance of the appliance**

The appliance, the flue connector piping and the flue must be cleaned regularly, particularly following long periods without use.

#### **4.1.1. Firebox**

Clean the firebox area of ash, etc.

#### **4.1.2. Inside the appliance**

Clean the firebox area of ash. Clean the deflectors, where soot may build up.

#### **4.1.3. Flue socket**

The flue socket area must be kept clean at all times for the appliance to work properly.

It must be cleaned as often as required. How often it is cleaned depends on how much the appliance is used and the type of fuel employed.

#### **4.1.4. Painted sheet-steel-cast-iron parts.**

These parts should be cleaned with a brush or dry cloth. Do not dampen the parts: the steel could rust and the paint could blister and chip. Be particularly careful when cleaning the glass: the liquids used must not dampen the painted steel.

#### **4.1.5. Firebox glass**

Keep the secondary-air intake open to keep the door glass cleaner for longer. However, the glass may get dirty the longer the appliance is used. Special degreasing products designed for the purpose should be used to clean it.

Clean when the glass is cold and taking care not to apply the glass cleaner directly onto the glass as it could come into contact with the door-seal cord and damage it.

Also make sure that the cleaning liquid does not enter the moving part of the intake mechanism; it may block the mechanism.

### **4.2. Maintenance of the chimney flue**

**VERY IMPORTANT:** In order to avoid incidents (chimney fires, etc.), it is necessary to perform maintenance and cleaning operations on a regular basis; if the appliance is used often, then the chimney and the flue connector piping must be swept several times a year.

In the event of fire in the chimney, close the flue draught, close doors and windows, remove embers from the firebox, block the connection hole with damp cloths and call the fire brigade.

### **4.3. Important advice**

Lacunza recommends that only Lacunza-authorized replacement parts be used.

Lacunza accepts no liability for any modification to the product which it has not authorised.





This appliance is a heat-producing appliance and contact may lead to burns.

This appliance may remain HOT for a period of time after it has gone out. **MAKE SURE THAT SMALL CHILDREN DO NOT GO NEAR IT.**

## 5. TROUBLESHOOTING



This symbol means that a qualified professional should be called to perform the operation.

Problem	Probable causes		Solution
<b>The fire does not light properly</b> <b>The fire does not stay alight</b>	Green or damp wood		Use hard woods, cut at least 2 years ago and stored in a sheltered, ventilated place
	The logs are too large		Use crumpled paper or firelighters and dry wood chips to light the fire. Use split logs to keep the fire going
	Poor-quality wood		Use hard woods which produce heat and embers (chestnut, ash, maple, birch, elm, beech, etc.)
	Insufficient primary air		Open the primary- and secondary-air intakes completely, or even open the door slightly. Open the outdoor-air inlet grille
	Insufficient updraught		Check that the draught is not blocked. De-soot if necessary. Check that the flue is in perfect condition (airtight, insulated, dry, etc.)
<b>The fire flames up too much</b>	Excessive primary air		Close the primary- and secondary-air intakes partially or totally
	Excessive updraught		Install a draught damper
<b>Smoke given off on lighting</b>	Poor-quality wood		Do not continually burn chips, carpentry scraps (plywood, pallets, etc.)
	Cold flue		Heat up the flue by burning a piece of paper in the firebox.
<b>Smoke during burning</b>	The room is at low pressure		In rooms with Controlled Mechanical Ventilation, leave an outdoor window ajar until the fire is fully alight.
	Too little wood loaded		Load as recommended. Loads notably smaller than those recommended lead to low smoke temperature and downdraught.
	Insufficient updraught		Check the condition of the flue and insulation. Check that the piping is not blocked. Clean mechanically if necessary
	Wind enters the flue		Install an anti-downdraught system (Cowl) at the top of the chimney
<b>Does not warm up enough</b>	The room is at low pressure		In rooms with Controlled Mechanical Ventilation, there must be an outdoor-air inlet
	Poor-quality wood		Only use the recommended fuel
<b>Water condenses (after the appliance has been lit more than 3 or 4 times)</b>	Too little wood loaded		Load as recommended. Loads notably smaller than those recommended lead to low smoke temperature and condensation.
	Green or damp wood		Use hard woods, cut at least 2 years ago and stored in a sheltered, ventilated place.
	Condition of the flue		Lengthen the flue (5-6 metres minimum). Insulate the flue properly. Check the airtightness of the flue/appliance.

## 6. BASIC BREAKDOWNS

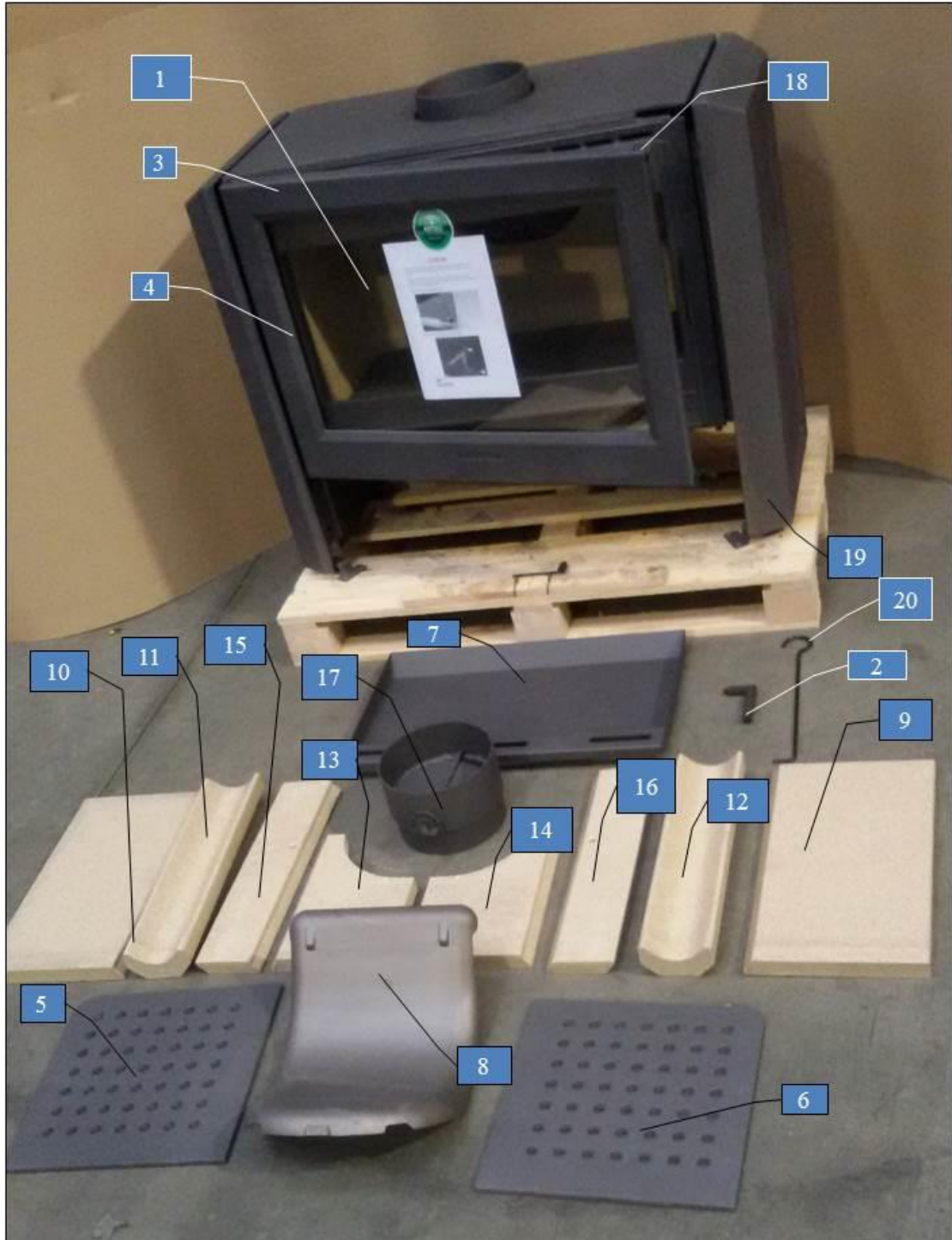

		<b>Leon</b>
<b>Numero</b>	<b>Denominación</b>	<b>Ref. Pieza</b>
1	Cristal puerta hogar	502230000748
2	Manilla puerta hogar	502230000763
3	Cordón puerta hogar (4m) Ø8mm	500900000010
4	Cordón plano entre cristal y puerta (3m) 12x3mm	500900000019
5	Parrilla izquierda hogar	502230000762
6	Parrilla derecha hogar	502230000761
7	Cajetín ceniza	502230000769
8	Deflector fundición	502230000764
9	Vermiculita costado derecho	502230000807
10	Vermiculita costado izquierdo	502230000806
11	Vermiculita esquina izquierda	502230000808
12	Vermiculita esquina derecha	502230000808
13	Vermiculita trasera-central-izquierda	502230000804
14	Vermiculita trasera-central-derecha	502230000805
15	Vermiculita trasera-izquierda estrecha	502230000809
16	Vermiculita trasera-derecha estrecha	502230000810
17	Conjunto Salida humos Clapeta cortatiros	502230000811
18	Varilla cierre manilla	502230000680
19	Pata	504090000021
20	Gancho	501000000017

## 7. DECLARATION OF PERFORMANCE



ES-S-014

**DECLARACIÓN DE PRESTACIONES** Conforme al R. E. Productos Construcción (UE) N° 305/2011

**DÉCLARATION DE PERFORMANCE** Selon le Règlement (UE) N° 305/2011

**DICHIARAZIONE DI PRESTAZIONE** In base al Regolamento (UE) N° 305/2011

**DECLARATION OF PERFORMANCE** According to Regulation (UE) N° 305/2011

**DECLARAÇÃO DE PRESTAÇÕES** Em base com o Regulamento (UE) N° 305/2011

1. Nombre y/o código de identificación única del producto:  
Nom-code d'identification unique du produit  
Nome-codice identificativo unico del prodotto  
Unique identifier nome-code for product  
Nome-código de identificação único do produto
  - Marca, marque, marca, mark, marca: LACUNZA
  - Tipo, type, tipo, type, tipo: Estufa, Poêle, Stufa, Stove, Aquecedor
  - Modelo, modèle, modello, model, modelo: **LEON**
2. Uso o usos previstos del producto: Estufa de carga manual, para quemar combustibles sólidos (Indicado en instrucciones), cuya función es calentar el espacio en el que está instalada.  
**Utilisation prévue du produit:** Poêle qui se charge manuellement, conçu pour brûler des combustibles solides (indiqués dans le Manuel d'Instructions), dont la fonction est de chauffer l'espace où il est installé.  
**Usi previsti del prodotto:** Stufa a carico manuale, per bruciare combustibili solidi (indicati nelle istruzioni), la cui funzione è riscaldare lo spazio in cui è installato.  
**Extended uses of the product:** Stove to be loaded by hand and designed to burn solid fuels (indicated in instructions), whose function is to heat the space in which it is installed.  
**Utilização prevista do produto:** Aquecedor de carga manual, para queimar combustíveis sólidos (indicado nas instruções), cuja função é aquecer o espaço no qual está instalado.
3. Nombre y dirección del fabricante: **LACUNZA KALOR GROUP S.A.L.**  
Nom et adresse du fabricant: **Pol. Ind. Ibarrea s/n 31800 Alsasua (Navarra) (España)**  
Nome e indirizzo del fabbricante: **Téléfono: (0034) 948563511**  
Name and address of the manufacturer: **Fax: (0034) 948563505**  
Nome e endereço do fabricante: **Email: comercial@lacunza.net**
4. Sistema de evaluación y verificación de la constancia de las prestaciones: 3  
Système d'évaluation et contrôle de la constance de performance: 3  
Sistema di valutazione e verifica della costanza della prestazione: 3  
Assessment and verification system for constancy of performance: 3  
Sistema de avaliação e verificação da regularidade do desempenho: 3
5. Organismo Notificado, Laboratoire notifié, Laboratorio notificato, Laboratory notified, Laboratório notificado:  
**RRF N° NB1625 Rhein-Ruhr Feuerstätten**  
**Prüfstelle GmbH**  
**Am Technologie Park 1 D-45307 ESSEN**  
Por el sistema, Selon le system, In base al system, Based on system, Em base ao system : 3.  
Documento emitido (fecha), Numéro du rapport d'essai (date), Numero rapporto di prova (data), Test report number (date), Número relação de prova (data): **40122967 (31-05-2012)**

6. Prestaciones declaradas, Performance déclarée, Prestazioni dichiarate, Services declare, Desempenhos declarados:

Especificaciones técnicas armonizadas, Spécifications techniques armonices, Specifica tecnica armonizzata, Harmonised technical specifications, Especifica técnica harmonizada EN13240:2001/A2:2004/AC:2006/AC:2007	
Características esenciales, Caractéristiques essentielles, Caratteristiche essenziali, Essential features, Características essenciais	Prestaciones, Performance, Prestazione, Services, Desempenho
Reacción al fuego, Resistance au feu, Resistenza al fuoco, Resistance to fire, Resistência ao fogo	Cumple, Conforme, Conforme, Compliant, Em Conformidade
Distancia mínima de seguridad a materiales combustibles, Distance minimum aux matériaux combustibles, Distanza mínima da materiali combustibili, Minimum distance from combustible material, Distância mínimo de materiais combustíveis	Izquierda, gauche, sinistra, left, esquerda: 400mm Derecha, droite, diritto, right, direito: 400mm Trasera, arrière, retro, back, traseira: 500mm Delantera, avant, fronte, front, frente: 1000mm Enclimera, dessus, sopra, above, acima: 750mm
Temperatura humos a potencia térmica nominal, Température des fumées, Temperatura fumi, Fume temperatura, Temperatura dos gases de combustão	413 °C
Emisión de productos de combustión, Emission des produits de combustion, Emisión prodotti combustione, Combustión productos emissions, Emissões de produtos de combustão	Cumple, Conforme, Conforme, Compliant, Em Conformidade
Concentración media CO al 13% O <sub>2</sub>	0.2 %
Desprendimiento de sustancias peligrosas	Cumple, Conforme, Conforme, Compliant, Em Conformidade
Temperatura superficial, Température de surface, Temperatura superficiale, Surface temperatura, Temperatura superficial	Cumple, Conforme, Conforme, Compliant, Em Conformidade
Seguridad eléctrica, Sécurité électrique, Sicurezza elettrica, Electrical safety, Segurança elétrica	-
Presión máxima de servicio (paila), Pression maximale de service, Máxima pressione di esercizio, Maximum operating pressure, Máxima pressão de exercício	-
Resistencia mecánica (para soportar una chimenea/un conducto de humos), Résistance mécanique (pour soutenir la cheminée), Resistenza mecánica (per supportare il camino), Mechanical strength (to support the fireplace), Resistência mecánica (para suportar a chaminé)	Cumple, Conforme, Conforme, Compliant, Em Conformidade
Potencia térmica ambiente, Puissance rendue au milieu, Potenza resa all'ambiente, Power output to the environment, Potência libertada no ambiente	20.4 kW
Potencia térmica agua, Puissance rendue à l'eau, Potenza ceduta all'acqua, Power transferred to water, Potência cedida à água	-
Rendimiento energético, Rendement, Rendimento, Efficiency, Atuação	78.2 %

Las prestaciones del producto identificado en el punto 1 son conformes con las prestaciones declaradas en el punto 6.  
 La performance du produit cité au point 1 est conforme à la performance declare au point 6.  
 La prestazione del prodotto di cui al punto 1 è conforme alla prestazione dichiarata di cui al punto 6.  
 The performance of the product referred to in point 1 is consistent with the declared performance in point 6.  
 As declarações do produto identificado no ponto 1, estão conformes com as prestações declaradas no ponto 6.

La presente declaración de prestaciones se emite bajo la única responsabilidad del fabricante, indicado en el punto 3.  
 Cette déclaration de performance est délivrée sous la responsabilité exclusive du fabricant cité au point 3.  
 Si rilascia la presente dichiarazione di prestazione sotto la responsabilità esclusiva del fabricante di cui al punto 3.  
 This declaration of performance is issued under the manufacturer's sole responsibility referred to in point 3.  
 É emitida a presente declaração de desempenho sob a responsabilidade exclusiva do fabricante referido no ponto 3.



Lacunza K&F Group S.A.  
 NIF A-30516132  
 Polígono Industrial Ibañeta, s/n  
 38800 Alsasua (Navarra) Spain

José Julián Garcíaandía Pellejero  
 Director Gerente

Alsasua 01-07-2013

**8. CE MARK**

 <b>12</b>	<b>LACUNZA KALOR GROUP S.A.L.</b> <b>Pol. Ind. Ibarrea s/n 31800</b> <b>Alsasua (Navarra) (Spain)</b>	
	Número, Nombre, Numero, Number, Número : <b>ES-S-014</b>	
Marca, marque, marca, mark, marca: <b>Lacunza</b> Tipo, type, tipo, type, tipo: <b>Estufa, Poêle, Stufa, Stove, Aquecedor</b> Modelo, modèle, modello, model, modelo: <b>LEON</b>	Organismo notificado, Laboratoire notifié, Laboratorio notificato, Laboratory notified, Laboratorio notificado: <b>RRF N° NB1625</b>	
<p>Estufa de carga manual, para quemar combustibles sólidos (indicado en instrucciones), cuya función es calentar el espacio en el que está instalada.</p> <p>Poêle qui se charge manuellement, conçu pour brûler des combustibles solides (indiqués dans le Manuel d'Instructions), dont la fonction est de chauffer l'espace où il est installé.</p> <p>Stufa a carico manuale, per bruciare combustibili solidi (indicati nelle istruzioni), la cui funzione è riscaldare lo spazio in cui è installato.</p> <p>Stove to be loaded by hand and designed to burn solid fuels (indicated in instructions), whose function is to heat the space in which it is installed.</p> <p>Aquecedor de carga manual, para queimar combustíveis sólidos (indicado nas instruções), cuja função é aquecer o espaço no qual está instalado.</p>		
<b>EN13240:2001/A2:2004/AC:2006/AC:2007</b>		
<b>Características esenciales, Caractéristiques essentielles, Caratteristiche essenziali, Essential features, Características essenciais</b>		<b>Prestaciones, Performance, Prestazione, Services, Desempenho</b>
Reacción al fuego, Resistance au feu, Resistenza al fuoco, Resistance to fire, Resistência ao fogo		<b>Cumple, Conforme, Conforme, Compliant, Em Conformidade</b>
Distancia mínima de seguridad a materiales combustibles, Distance minimum aux matériaux combustibles, Distanza minima da materiali combustibili, Minimum distance from combustible material, Distância mínimo de materiais combustíveis	<b>Izquierda, gauche, sinistra, left, esquerda: 400mm</b> <b>Derecha, droite, diritto, right, direito: 400mm</b> <b>Trasera, arrière, retro, back, traseira: 500mm</b> <b>Delantera, avant, fronte, front, frente: 1000mm</b> <b>Encimera, dessus, sopra, above, acima: 750mm</b>	
Temperatura humos a potencia térmica nominal, Température des fumées, Temperatura fumi, Fume temperatura, Temperatura dos gases de combustão	<b>413 °C</b>	
Emisión productos combustión, Emisión des produits de combustion, Emisión prodotti combustione, Combustión productos emissions, Emissões de produtos de combustão	<b>Cumple, Conforme, Conforme, Compliant, Em Conformidade</b>	
Concentración media CO al 13% O2, Concentration moyenne CO al 13% O2, CO concentrazione media di O2%, Average concentration CO to O2%, CO concentração média de O2%	<b>0.2 %</b>	
Desprendimiento de sustancias peligrosas, Rejet de substances dangereuses, Rilascio di sostanze pericolose, Release of hazardous substances, Lançamento de substâncias perigosas	<b>Cumple, Conforme, Conforme, Compliant, Em Conformidade</b>	
Temperatura superficial, Température de surface, Temperatura superficiale, Surface temperatura, Temperatura superficial	<b>Cumple, Conforme, Conforme, Compliant, Em Conformidade</b>	
Seguridad eléctrica, Sécurité électrique, Sicurezza elettrica, Electrical safety, Segurança elétrica	<b>-</b>	
Presión máxima de servicio (paila), Pression maximale de service, Máxima pressione di esercizio, Maximum operating pressure, Máxima pressão de exercício	<b>-</b>	
Resistencia mecánica (para soportar una chimenea/un conducto de humos), Resistence mécanique (pour soutenir la cheminée), Resistenza mecánica (per supportare il camino), Mechanical strength (to support the fireplace), Resistência mecânica (para suportar a chaminé)	<b>Cumple, Conforme, Conforme, Compliant, Em Conformidade</b>	
Potencia térmica ambiente, Puissance rendue au milieu, Potenza resa all'ambiente, Power output to the environment, Potência libertada no ambiente	<b>20.4 kW</b>	
Potencia térmica agua, Puissance rendue à l'eau, Potenza ceduta all'acqua, Power transferred to water, Potência cedida à água	<b>-</b>	
Rendimiento energético, Rendement, Rendimento, Efficiency, Atuação	<b>78.2 %</b>	

LACUNZA KALOR GROUP S.A.L

Pol. Ind. Ibarrea s/n

31800 Alsasua (Navarra) Spain

Tel.: (00 34) 948 56 35 11

Fax.: (00 34) 948 56 35 05

e-mail: [comercial@lacunza.net](mailto:comercial@lacunza.net)

Website: [www.lacunza.net](http://www.lacunza.net)

EDITION: 0

