

GV Series

GAS COMBINATION CONTROL SYSTEMS



Precision Engineering for Multiple Markets

MERTIK MAXITROL

Exclusive Distributor for Maxitrol Company

GV Series

GAS COMBINATION CONTROL SYSTEMS

3	GENERAL INFORMATION - APPLICATIONS - VERSIONS
4	FEATURES & OPTIONS - CONNECTIONS
5	TECHNICAL DATA - OVERVIEW
6	WORKING DIAGRAM - PRESSURE DROP
7	VALVE FUNCTION - GV30
8	DIMENSIONS AND WEIGHTS
9	GV30 - GV31
10	GV32 - GV33
11	GV34 - GV36
12	GV38 - GV60
13	GV-560
14	R300 REMOTE CONTROL SYSTEMS
15	R300 REMOTE CONTROL SYSTEMS - OPERATION
16	GV34 - ELECTRONIC OPTIONS - CABLES
17	GV30 - ACCESSORIES AND REPLACEMENT PARTS
18	GV60 - HANDSETS
19	GV60 - OPERATION
20	GV60 - ELECTRONIC OPTIONS - CABLES
21	GV60 - ACCESSORIES AND REPLACEMENT PARTS
22-23	COMMERCIAL COOKING





GENERAL INFORMATION

The GV Series is a comprehensive line of gas combination control systems used to control the pilot and main burner.

In addition to its standard features and options, this unique system can be customized for use on a wide range of appliances such as space heaters, fireplaces, griddle plates, storage water heaters, or ovens. The GV Series has four configurations: manual control, hydraulic thermostat control, battery operated remote control, or battery (or line power) operated remote ignition and remote control.

All versions of the GV valve have the same footprint, allowing an appliance to be upgraded without redesigning the vestibule. An appliance can be upgraded from a manual control system to a battery operated remote control system simply by adding accessories.

APPLICATIONS

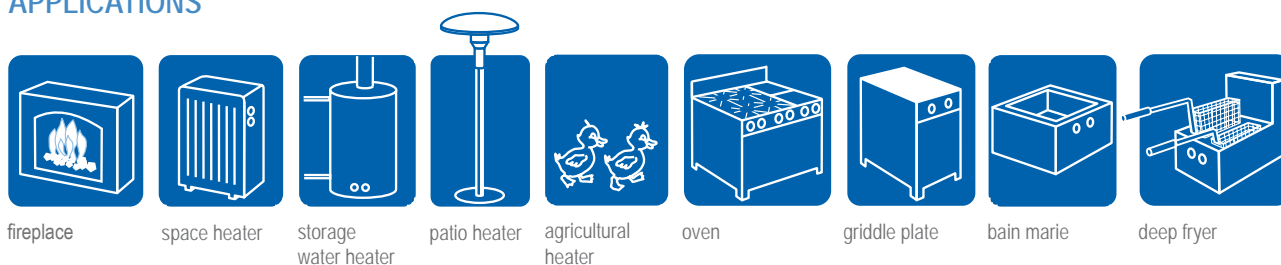

fireplace

space heater

storage water heater

patio heater

agricultural heater

oven

griddle plate

bain marie

deep fryer

VERSIONS

Manual control (GV32)

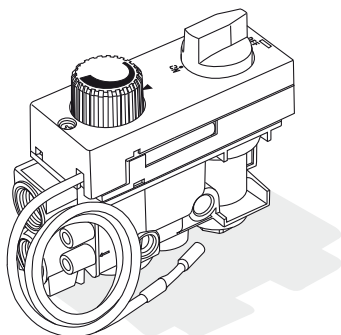

Temperature control (GV30, GV31, GV33)

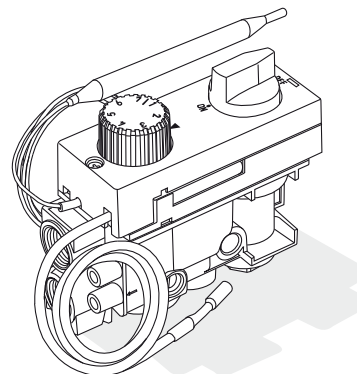

Battery operated remote control (GV34)

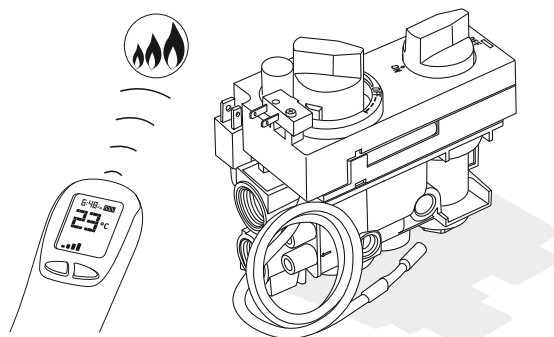

Battery operated remote ignition and control (GV60)

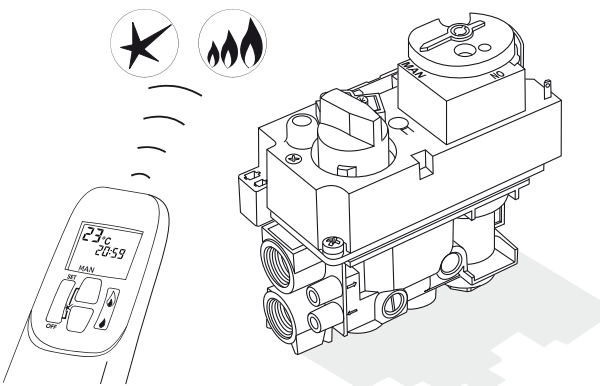

FEATURES & OPTIONS GV30 SERIES

- Compact design
- Easy operation:
 - Separate temperature knob
 - Stand-by position independent of temperature setting
- Thermo-electric flame failure device
- Interlock prevents inadvertent reignition (for CSA only: optional without interlock)
- Integrated piezo ignitor (optional)
- Min. rate setting with fixed or adjustable orifices (vented only)
- Pilot gas adjustment screw
- Pilot gas filter
- Screen in gas inlet area (optional, for CE version standard)
- Inlet/outlet connections at bottom, side, or both, providing various inlet/outlet combinations
- Liquid filled temperature sensor
- Compensator for ambient temperature effects (optional)
- Manual or motor controlled setting instead of the temperature regulator (optional)
- Side outlet for 2nd burner (i.e. for wood or coal fire simulation) independent from the temperature regulator setting with knob for 2nd burner (optional)
- Integrated pressure regulator (optional) or throttle (CE only)
- Convertible pressure regulator (optional, CSA only)
- Battery holder with connection for switch panel (optional)

FEATURES & OPTIONS GV60 SERIES

- Compact design
- Programmable handset with electronic ignition
- Manual ignition with piezo ignitor (optional)
- Thermo-electric flame failure device
- Min. rate setting with fixed or adjustable orifices (vented only)
- Pilot gas adjustment screw
- Pilot gas filter
- Screen in gas inlet area (optional, for CE version standard)
- Inlet/outlet connections at bottom, side, or both, providing various inlet/outlet combinations
- Integrated pressure regulator (optional) or throttle (CE only)
- Convertible pressure regulator (optional, CSA only)
- Designated low/high fire setting
- Variable ambient light control and circulating fan control via handset (optional)
- Connection for exhaust fan control
- GV-S60 latching solenoid (optional)
- Second thermocouple connection (optional)
- Receiver with connection for wall switch, switch panel or touch pad (optional)

CONNECTIONS

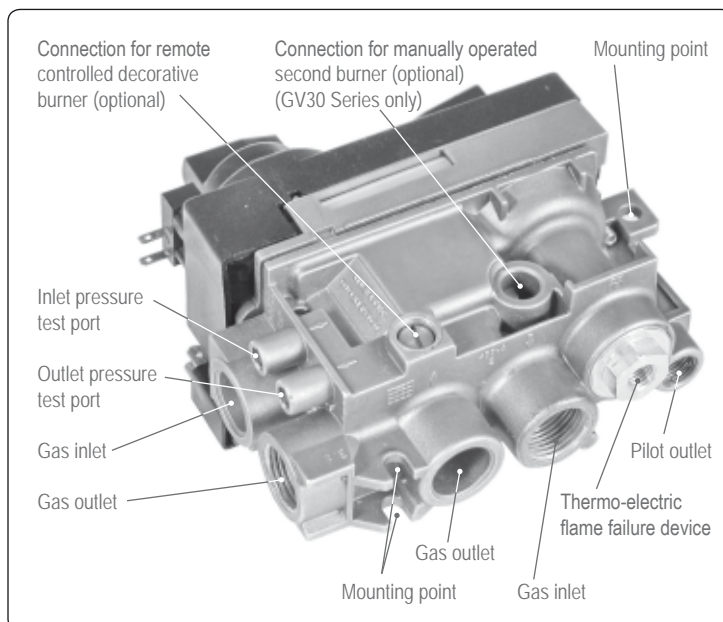

Illustration 1: GV Series - Connections

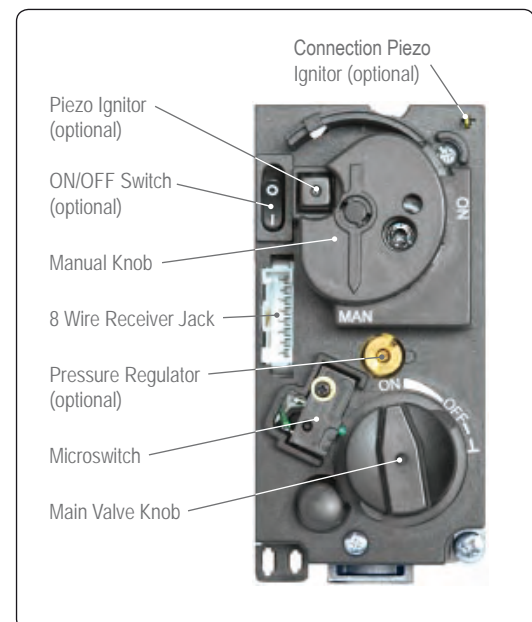

Illustration 2: GV60 - Top view

FEATURES & OPTIONS - CONNECTIONS



TECHNICAL DATA

	CE-Certification	CSA-Certification
Maximum Operating Pressure	5 kPa (20" w.c.)	1/2 psi (3.45 kPa)
Capacity	up to 1.45 m ³ /h air at 0.25 kPa pressure drop	up to 65,000 BTU at 1" w.c. pressure drop
Ambient Temperature		
Gas Combination Control - Standard	0° to 80°C	32° to 176°F
Gas Combination Control - Optional	0° to 110°C	32° to 230°F
GV34/GV38 Receiver	0° to 60°C	32° to 140°F
GV60 Receiver (Radio Frequency)	0° to 80°C	32° to 176°F
GV60 Receiver (Infrared)	0° to 60°C	32° to 140°F
Integral Pressure Regulator	class C according to EN88 adj. range 0.5 - 4 kPa	10,000 to 85,000 BTU/hr (ANSI 21.18) adj. range 3" - 12" w.c.
Pipe Connection Thread (various inlet/outlet combinations)	Rp 3/8 DIN 10226-1/ ISO 7-1	3/8" NPT or Loxit, R 3/8"

1 kPa = 10 mbar = 4.015" w.c.

OVERVIEW

Type	Main Valve Function			Main Burner Control				2nd Burner Control	
	Shut-off & High	Low to High	Shut-off & Low to High	Manual Control	Temperature Control	Temperature & Remote Control	Remote Control	Manual Control	Remote Control
Possible conversion to motorized valves	GV30		✓		✓			✓	
	GV31	✓			✓			✓	
	GV32		✓		✓			✓	
	GV33		✓			✓		✓	
	GV34			✓			✓	✓	✓
	GV36			✓	✓			✓	
	GV38			✓			✓	✓	✓
	GV60			✓			✓		✓

WORKING DIAGRAM

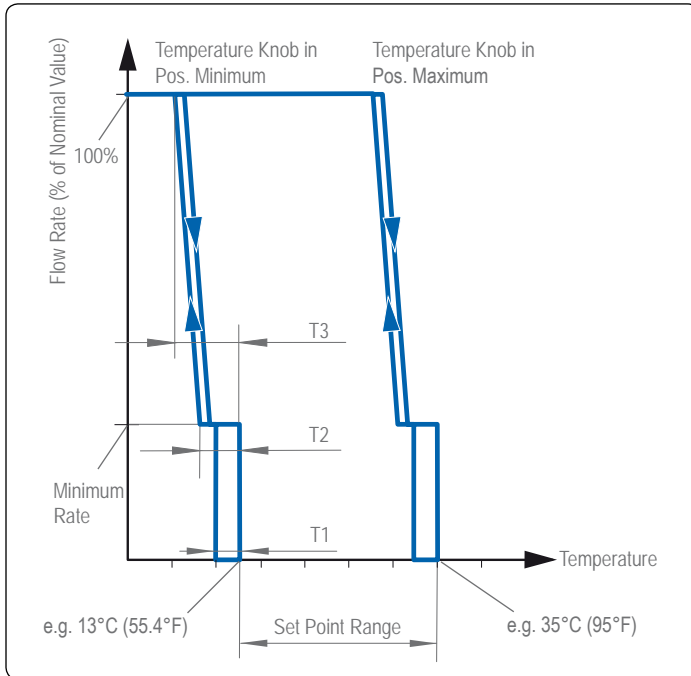

Illustration 3: Working Diagram (Example for set point range 13° to 35°C/55.4° to 95°F)

Set Point Range	T1 ¹ [K]	T2 [K]	T3 [K]	T _{max} ²
13° to 35°C 55.4° to 95°F	2.7	< 4.5	< 7	50°C 122°F
40° to 90°C 104° to 194°F	6	< 10	< 16	110°C 230°F
30° to 110°C 86° to 230°F	8	< 13	< 20	180°C 356°F
66° to 260°C 150.8° to 500°F	14	< 22	< 35	350°C 662°F
110° to 190°C 230° to 374°F	6	< 10	< 15	260°C 500°F
100° to 340°C 212° to 644°F	17	< 28	< 43	350°C 662°F

¹ Mean Value

² Maximum Bulb Temperature

PRESSURE DROP

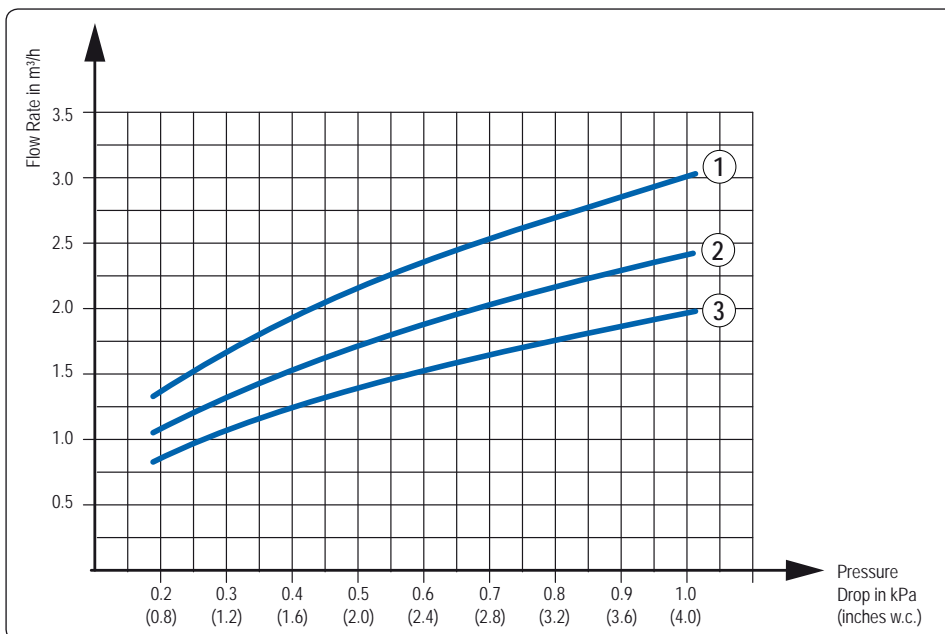
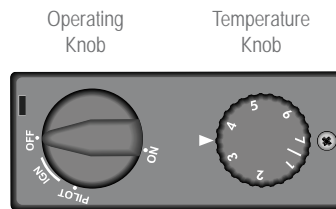
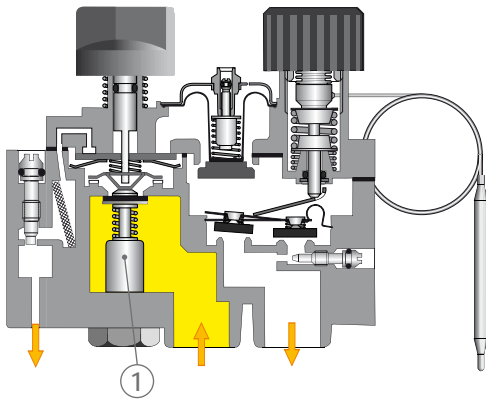

Illustration 4: Pressure Drop Diagram (standard version)

1 kPa = 10 mbar = 4.015" w.c.



VALVE FUNCTION - GV30



Off

Operating knob is in OFF position.
The thermo-electric flame failure device ① is closed.

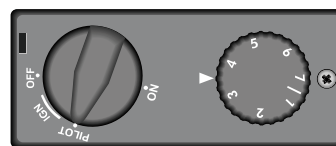
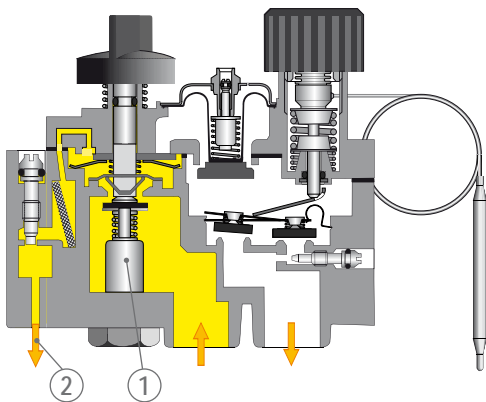

Ignition

The operating knob is in PILOT position and pressed down.
The thermo-electric flame failure device ① is open allowing gas flow to the pilot burner ②.

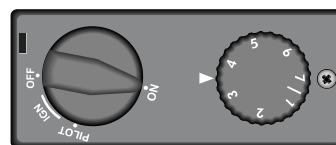
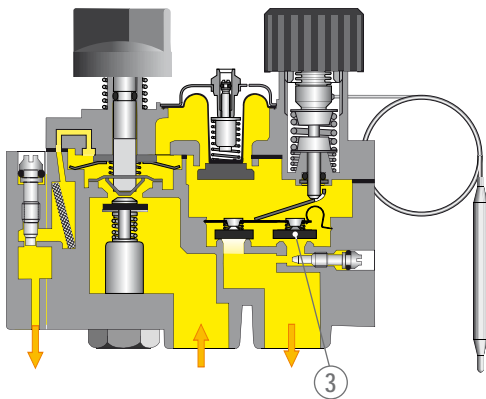

Low fire

The operating knob is in ON position.
The room temperature is slightly lower than the set temperature.
Gas flows through the low fire ON-OFF valve ③.

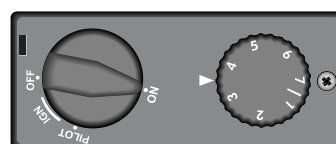
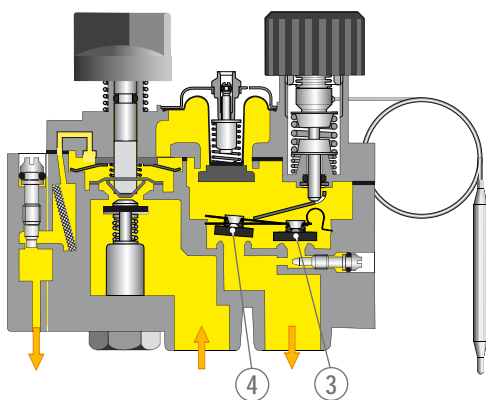

High Fire

The operating knob is in ON position.
The room temperature is lower than the set temperature.
Gas flows through the high fire modulation valve ④ and low fire ON-OFF valve ③.

DIMENSIONS AND WEIGHTS

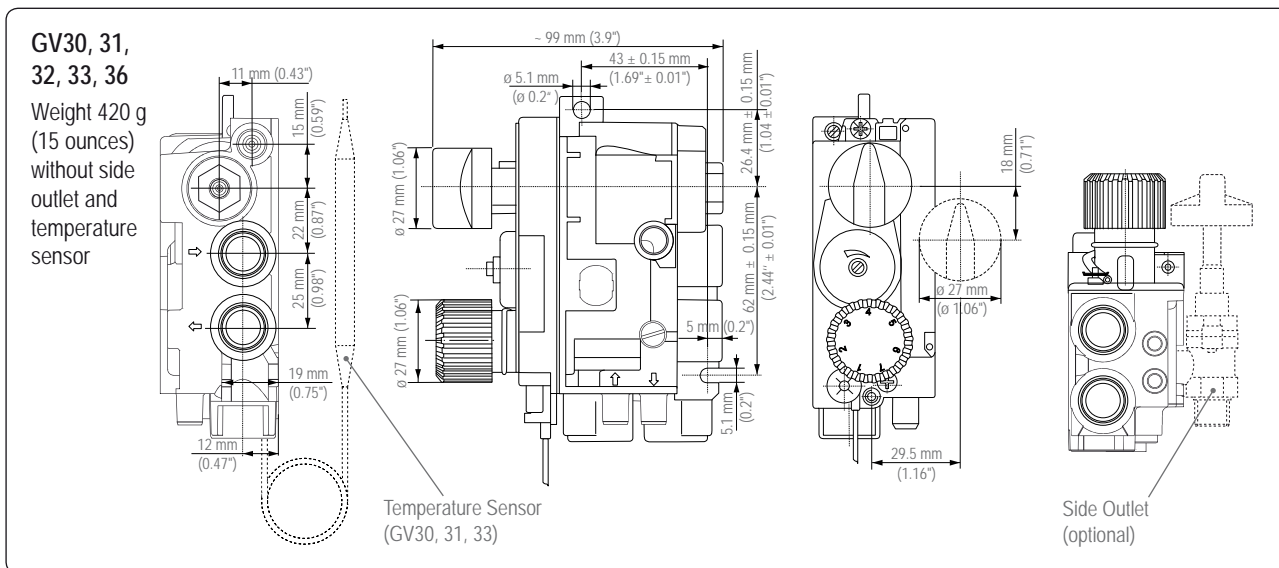

Illustration 5: GV30, 31, 32, 33, 36 - Dimensions and Weight

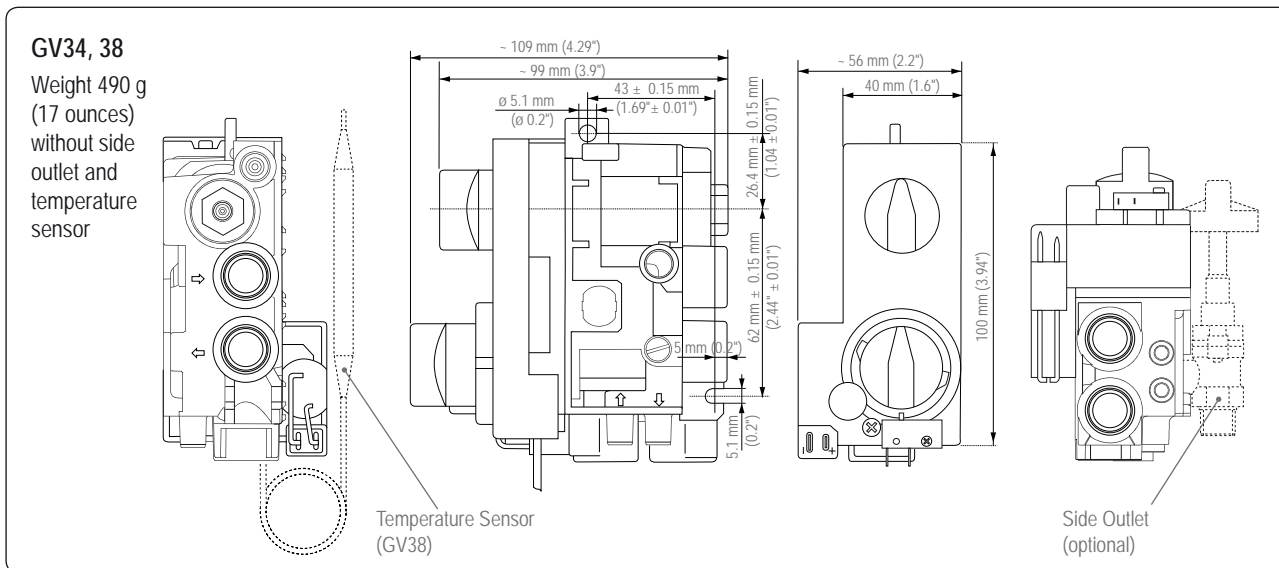

Illustration 6: GV34, 38 - Dimensions and Weight

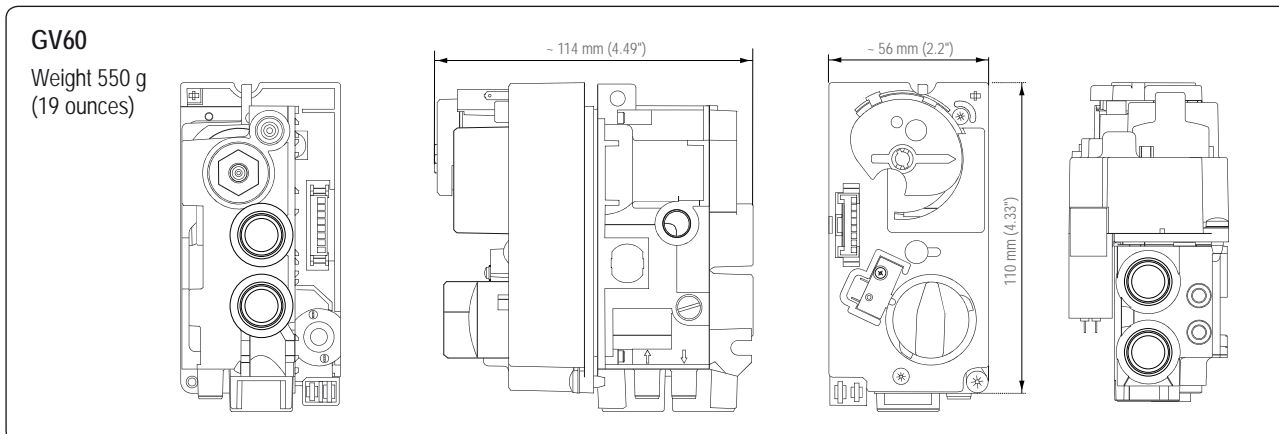

Illustration 7: GV60 Series - Dimensions and Weight

DIMENSIONS AND WEIGHTS



GV30



space heater



agricultural heater



oven



griddle plate



bain marie



deep fryer

The GV30 is a thermostatically controlled, modulating valve that maintains a set point temperature. Once set point temperature is reached, the valve supplies only the amount of gas required to maintain that temperature. The valve can be converted to GV38 for applications with temperature control. The GV30 is fully enclosed for added protection.

- Operation: temperature controlled
- Temperature Sensors: various ranges between 13°C (55.4°F) to 340°C (644°F)
- Integrated piezo ignitor (optional)
- Integrated pressure regulator (optional) or throttle (CE only)
- Customized to OEM specifications

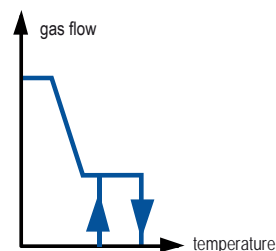
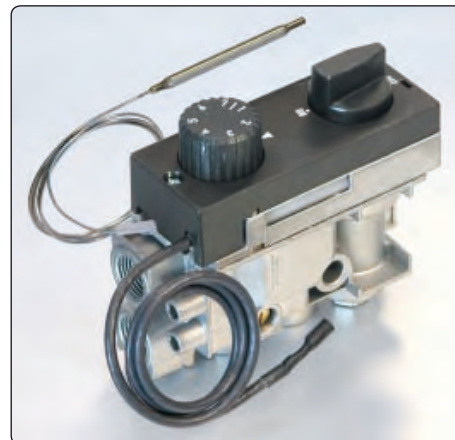

Main valve function: Shut-off Low to High

GV31



space heater



storage water heater



agricultural heater



oven



bain marie



deep fryer

A thermostatically controlled ON/OFF valve, the GV31 operates at maximum capacity until the set point temperature is achieved, and then it snaps off. The GV31 is fully enclosed for added protection.

- Operation: temperature controlled
- Temperature Sensors: various ranges between 13°C (55.4°F) to 340°C (644°F)
- Integrated piezo ignitor (optional)
- Integrated pressure regulator (optional) or throttle (CE only)
- Customized to OEM specifications

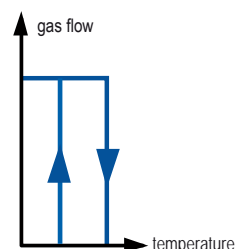
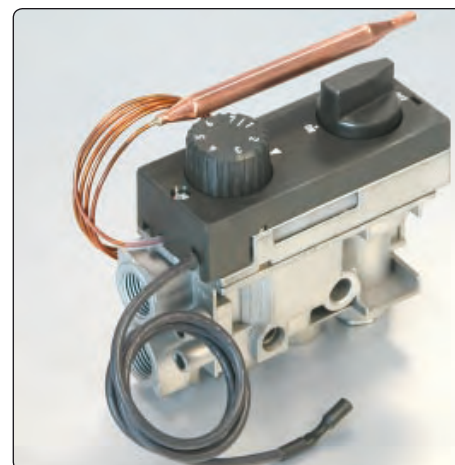

Main valve function: Shut-off & High

GV32



fireplace



patio heater

The GV32 is manually operated and is adjustable between low fire and high fire. At low fire the GV32 still provides heat and, as applied to fireplaces and log sets, an aesthetically pleasing flame.

- Operation: manually controlled
- Integrated piezo ignitor
- Integrated pressure regulator (optional) or throttle (CE only)
- Customized to OEM specifications

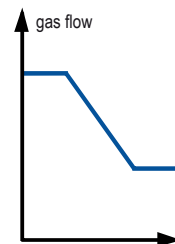

Main valve adjustment: Low to High

GV33



space heater



agricultural heater

After reaching the set point temperature, the thermostatically controlled GV33 goes to low fire without shutting off. When called for, the GV33 quickly provides additional heat.

- Operation: temperature controlled
- Temperature Sensors: various ranges between 13°C (55.4°F) to 340°C (644°F)
- Integrated piezo ignitor (optional)
- Integrated pressure regulator (optional) or throttle (CE only)
- Customized to OEM specifications

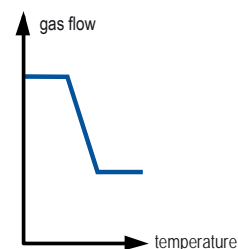
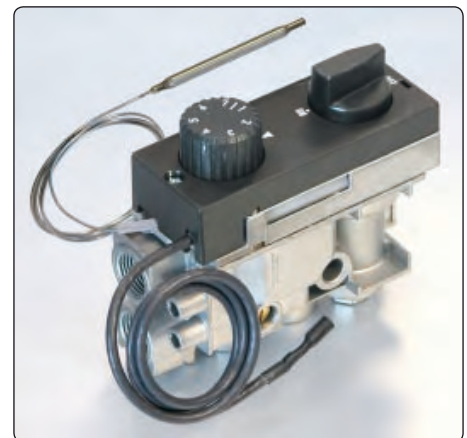

Main valve function: Low to High



GV34



fireplace



space heater

The GV34 is a servo motor operated valve with remote control allowing for infinite adjustment from low fire to high fire. When used with thermostatic handset, the GV34 fully modulates from low fire to high fire.

- Operation:
 - Battery operated handset
 - Temperature sensing handset with timer function
 - Manual override
- Radio frequency or ultrasound transmission
- Integrated piezo ignitor (optional)
- Integrated pressure regulator (optional) or throttle (CE only)
- Customized to OEM specifications

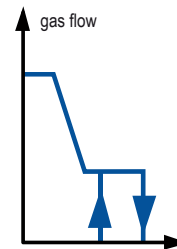

Main valve function: Shut-off Low to High

GV36



fireplace



oven



griddle plate



bain marie

The GV36 valve is manually operated to adjust the flame height. It can be easily upgraded with a motor and gear assembly to a GV34 for use with remote control system.

- Operation: manually controlled
- Integrated piezo ignitor (optional)
- Integrated pressure regulator (optional) or throttle (CE only)
- Customized to OEM specifications

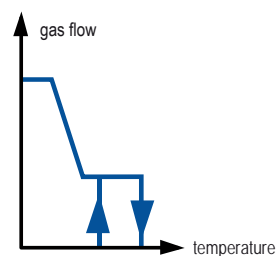
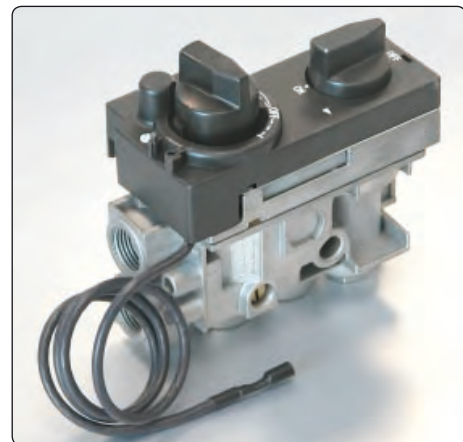

Main valve function: Shut-off Low to High

GV38



fireplace



space heater



oven

The GV38 is a thermostatically controlled, modulating valve that maintains set point temperature for space heating. Temperature adjustment is by manual or remote control.

- Operation: - Battery operated handset
 - Temperature sensing handset with timer function
 - Manual override
- Temperature Sensors: various ranges between 13°C (55.4°F) to 340°C (644°F)
- Radio frequency or ultrasound transmission
- Integrated piezo ignitor (optional)
- Integrated pressure regulator (optional) or throttle (CE only)
- Customized to OEM specifications

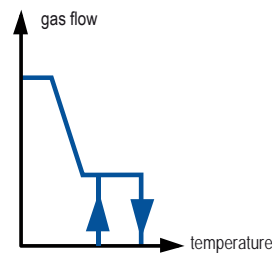
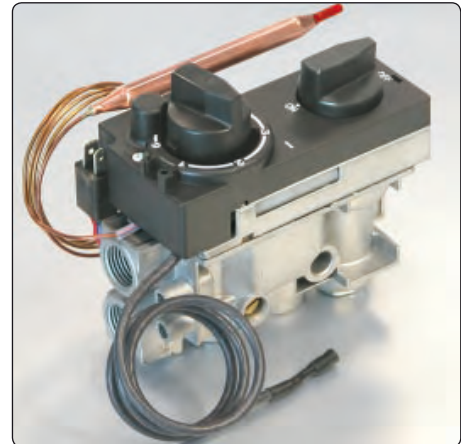

Main valve function: Shut-off Low to High

GV60



fireplace



patio heater

The GV60 remote ignition and control system operates in conjunction with standard pilot burner and ODS systems. When used with thermostatic handset, the GV60 fully modulates between low fire and high fire.

- Operation: - Battery operated handset
 - Temperature sensing handset with timer function
 - Manual override
 - Low battery consumption
- Radio frequency (RF) or infrared transmission (IR)
- Second thermocouple connection for main burner
- Variable ambient light control (RF version only)
- Circulating fan control with 4 speed levels and OFF (RF version only)
- Integrated piezo ignitor (optional) for manual override
- Integrated pressure regulator (optional) or throttle (CE only)
- Customized to OEM specifications
- Connection for exhaust fan control
- Connection for GV-S60 latching solenoid for second burner control
- Designated low/high fire setting

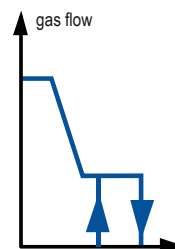
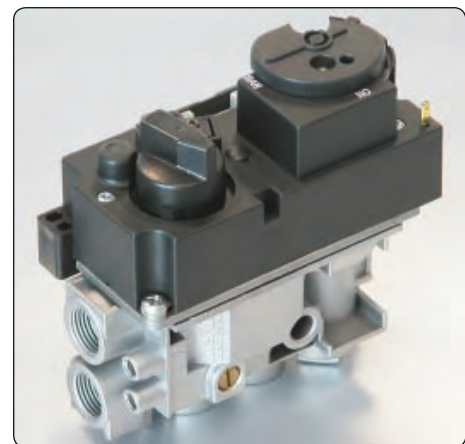

Main valve function: Shut-off Low to High

GV38 - GV60



GV-S60



fireplace

The GV-S60 is a battery operated latching solenoid valve for controlling two burner applications. Both burners must have flame supervision from the same pilot source (one ignition for both burners). It is for use on hearth products that incorporate a separate, decorative burner and are controlled by Mertik Maxitrol GV60 electronics. When the latching solenoid valve is attached to the GV60 main burner outlet, the main burner can be switched OFF while the decorative burner remains ON.

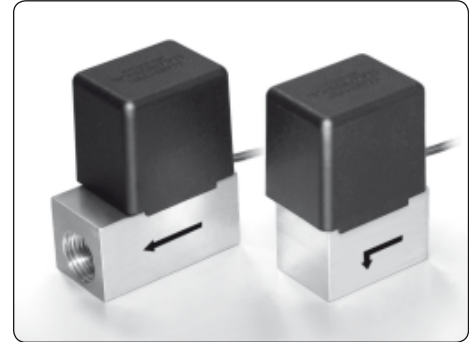

	CE-Certification	CSA-Certification
Maximum Operating Inlet Pressure	5 kPa (20" w.c.)	1/2 psi (3.45 kPa)
Ambient Temperature	0°C to 80°C (0°C to 110°C optional)	32°F to 176°F (32°F to 230°F optional)
Gas Inlet Connection / Gas Outlet Connection	Rp 3/8 DIN 10226-1/ISO 7-1	Rp 3/8 DIN 10226-1/ ISO 7-1 / M12x1 for 8 mm tube
Capacity	1 m ³ /h at 0.25 kPa pressure drop / 45,000 BTU/hr* of 1" w.c. pressure drop	

*The capacity is based on natural gas having a heating value of 1,000 Btu/ft³ (10.35 kWh/m³), and a specific gravity of 0.64.

1 kPa = 10 mbar = 4.015" w.c.

R300 REMOTE CONTROL SYSTEMS (for GV34 & GV38)

Radio Frequency	Europe 868 MHz, U.S./Canada 915 MHz
Ambient Temperature	
Handset	max. 60°C (140°F)
Receiver	max. 60°C (140°F)
Connecting Cable	max. 180°C (365°F)
Weight (without batteries)	
Handset	50 g (2 ounces)
Receiver (without cable)	75 g (3 ounces)
Batteries	
Handset	2 x 1.5 V AAA (low battery indication)
Receiver	4 x 1.5 V AA (low battery indication)









	Ambient Temperature Display (°F or °C)
	Battery Life Indicator
	Clock (12 or 24 hour)
	Communication Indicator
	Child Safety Lock
	Timer OFF/Sleep Mode
	Timer On (equipped with two timers)
	Automatic Temperature Control
	Temperature Range Indicator

Illustration 8: Icons on Display



Illustration 9: R300 Remote Control Systems

¹ The Handset is intended for use with motorized gas combination control models GV34 (or GV36 retrofitted with a motor and gear assembly).

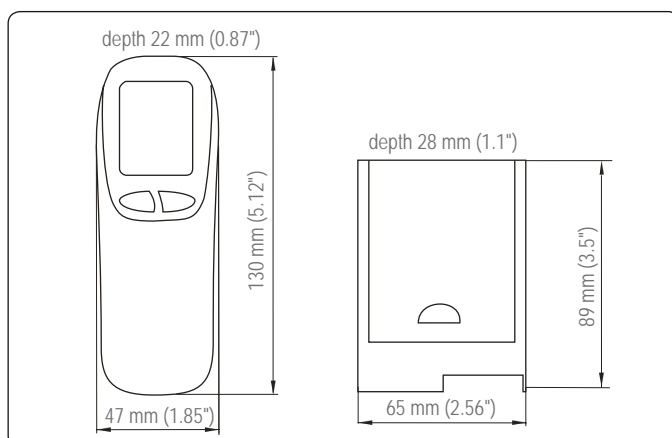

Illustration 10: Dimensions Handset and Receiver

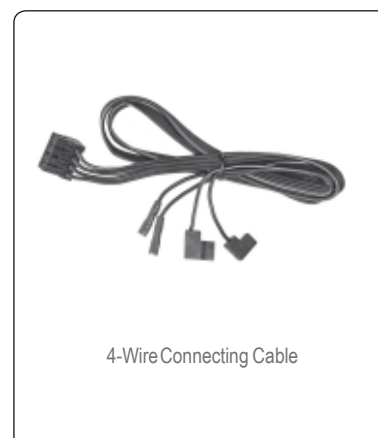

Illustration 11: GV34, 38-Cable (included in handset/receiver set)

R300 REMOTE CONTROL SYSTEMS



R300 REMOTE CONTROL SYSTEMS - OPERATION

Modes of Operation

Press and release both buttons on Handset to change the mode of operation in the following order:

1. Manual mode ^{1,2}

- Manual flame height adjustment via buttons  on Handset.



2. Thermostatic Mode ²

- Room temperature is measured and compared to the set temperature.
- Flame height is then automatically adjusted to achieve the set temperature.



3. Timer Mode ²

- Timer 1 and 2 each can be programmed to go ON and OFF at specific times.

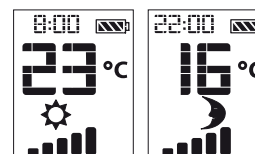

Child Safety Lock ^{1,2}

- When ON the right button must be pushed twice within 0.5 seconds to increase flame height.



Sleep Mode ^{1,2}

- After 8 hours of no signal between the handset and receiver, valve runs to pilot.



¹ Standard Handset

² Thermostat & Timer Handset

GV34 - ELECTRONIC OPTIONS

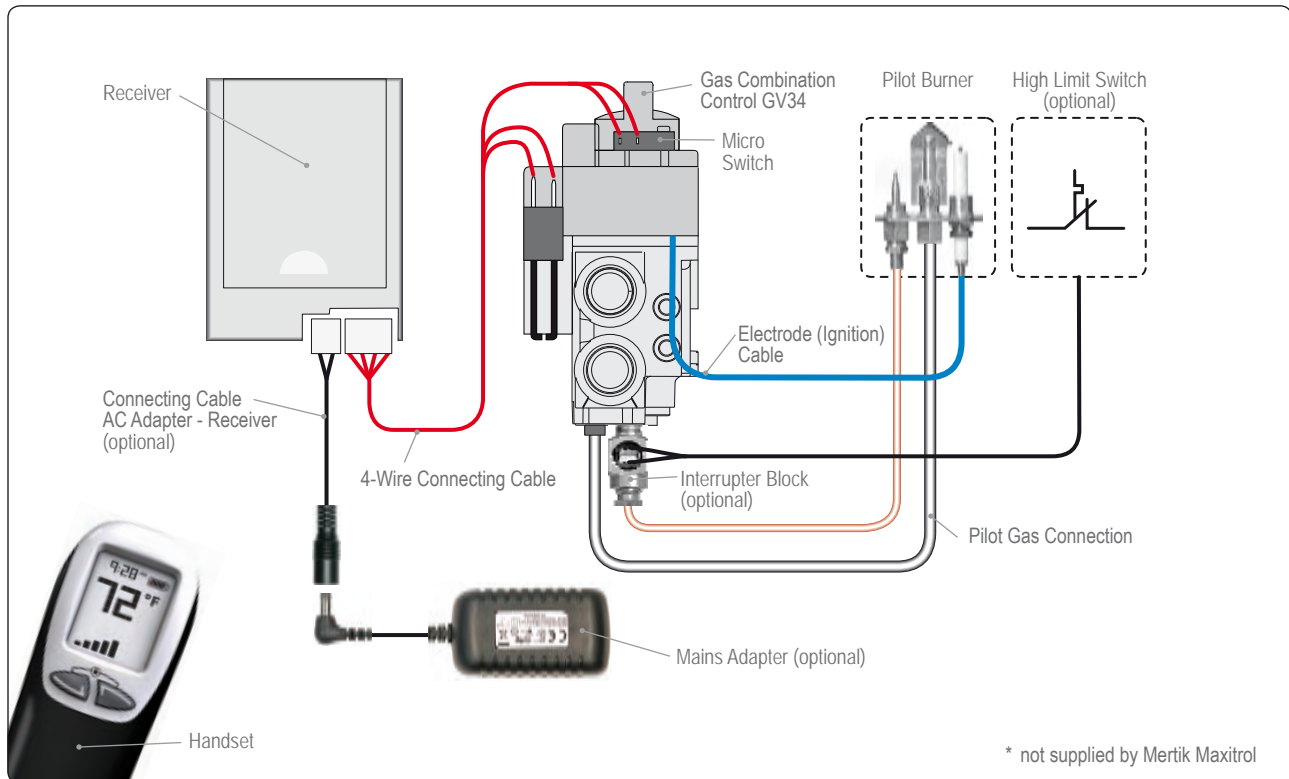

Illustration 12: GV34 - Electronic Options

CABLES

G30-ZRCP	
4-wire connecting cable	Connecting Cable AC Adapter - Receiver
Length [mm]	Length [mm]
350	80
800	



GV30 - ACCESSORIES AND REPLACEMENT PARTS (more available on request)

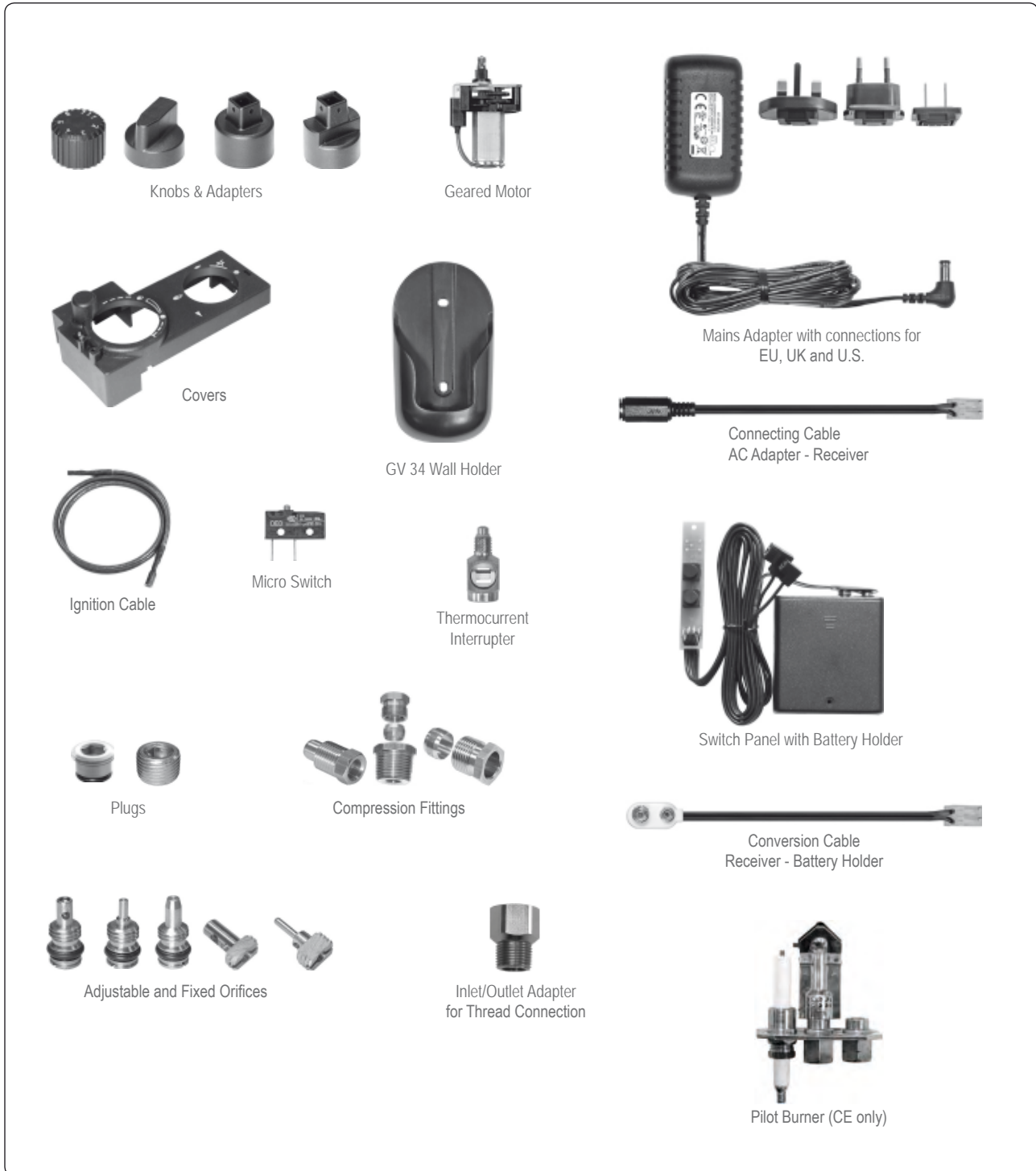

Illustration 13: GV30 Series - Accessories and Replacement Parts

GV60 - HANDSETS

Radio Frequency Transmission (RF) Infrared Transmission (IR)*

Europe 433.92 MHz; U.S. 315 MHz (FCC ID: RTD-G6R) and Canada (IC: 4943A-G6R)	Wave-Length 940 nm ± 50 nm Working Range 0.5 m (1.6') to 10 m (32.8') line-of-sight to infrared sensor required
------------------------------------------------------------------------------------	-----------------------------------------------------------------------------------------------------------------------

Ambient Temperature (without batteries)	
Handset	max. 60°C (140°F)
Receiver (RF)	max. 80°C (176°F)
Receiver (IR)	max. 60°C (140°F)
Connecting Cable & Thermocurrent Cable	
Ignition Cable	max. 105°C (221°F)
Ignition Cable	max. 150°C (302°F)
Infrared Sensor	max. 80°C (176°F)

Weight (without batteries)

Handset	65 g (2.5 ounces)
Receiver	190 g (7 ounces)

Batteries

Handset	1 x 9 V
Receiver	4 x 1.5 VAA

* Handset according to Gadac Guidance Sheet B12, 10/2004







	Ambient Temperature Display (°F or °C)
	Battery Life Indicator
	Clock (12 or 24 hour)
	Communication Indicator
	Circulating Fan
	Light/Dimmer
	Day-/Nighttime Temperature Mode
TIMER	Timer Mode
MAN	MAN Mode
P1 P2	Timer (equipped with two timers)
AUX	Latching Solenid

Illustration 14: Icons on Display

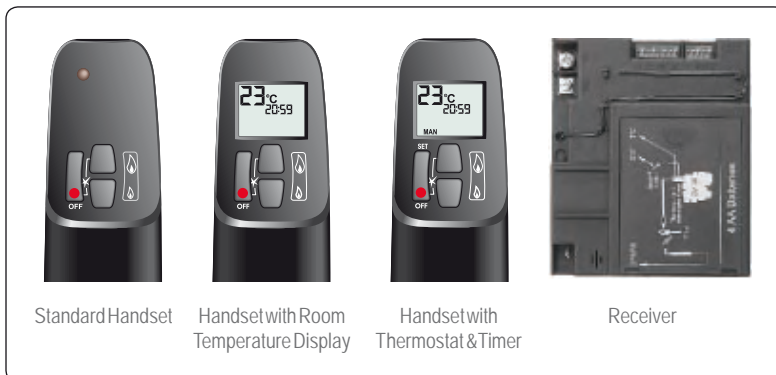

Illustration 15: Handsets/Receiver for Radio Frequency Transmission (RF)

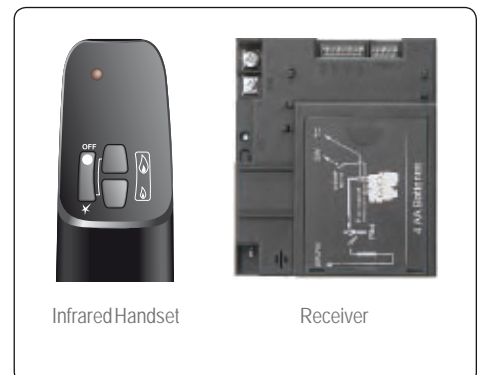

Illustration 16: Handset/Receiver for Infrared Transmission (IR)

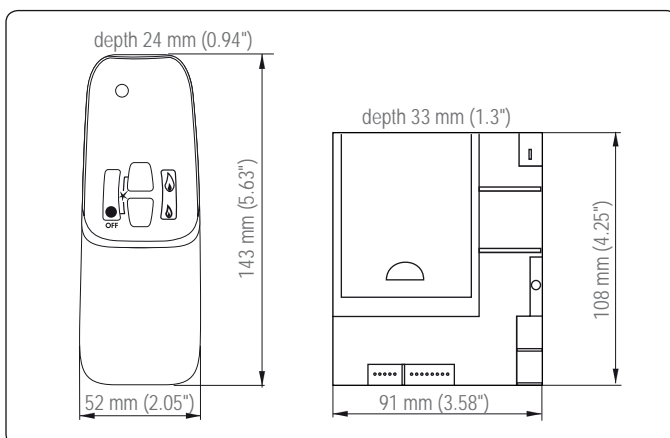

Illustration 17: GV60 - Dimensions Handset and Receiver

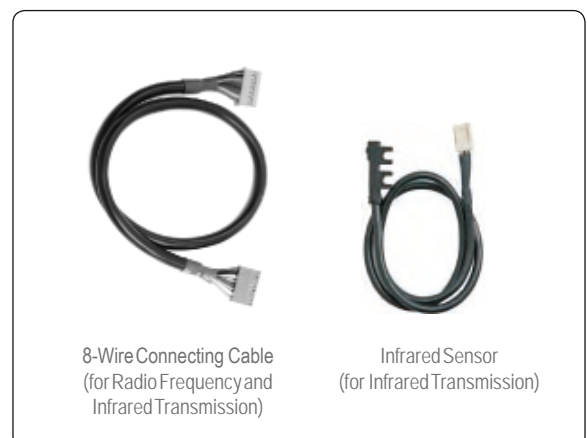

Illustration 18: GV60 - Cable (included in Handset/Receiver Set)

GV60 - HANDSETS



GV60 - OPERATION

Modes of Operation

Briefly press the SET button on Handset to change the mode of operation in the following order:

1. Manual Mode ²

- Manual flame height adjustment via buttons  (large flame) or  (small flame) on Handset.

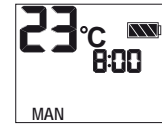

2. Daytime Temperature Mode ²

- Room temperature is measured and compared to the set temperature.
- Flame height is then automatically adjusted to achieve the Daytime Set Temperature.



3. Light/Dimmer Setting Mode ^{1,2}

- Turns light/dimmer ON and OFF and adjusts brightness.
- Light ON but no flame is also possible.

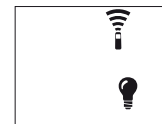

4. Circulating Fan Setting Mode ^{1,2}

- Turns circulating fan ON and OFF and adjusts fan speed (4 speed levels from low to high).
- Fan starts 4 minutes after the gas opens at maximum speed and goes to the displayed level after 10 seconds.
- Fan stops 10 minutes after the gas is OFF or at pilot.

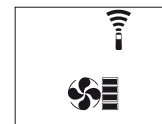

5. Nighttime Setback Temperature Mode ²

- Room temperature is measured and compared to the set temperature.
- Flame height is then automatically adjusted to achieve the Nighttime Setback Temperature.

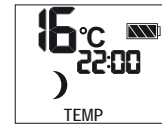

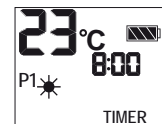

6. Timer Mode ²

- Timer P1 and P2 (Program 1, Program 2) each can be programmed to go ON and OFF at specific times.
- Set temperature will be shown every 30 seconds on the display.



Designated Low and High Fire Setting ^{1,2}

- Double-click  (small flame) button. Flame will automatically go to low fire.
- Double-click  (large flame) button. Flame will automatically go to high fire.



Second Thermocouple Option

- Second thermocouple is placed in the main burner in order to check that the main gas is ignited within a certain time after opening.
- Voltage will be measured T1 (22 sec) after the motor has turned in high fire direction (after ignition and after increasing flame height).
- If than the voltage is lower than 1.8mV, the electronic shuts off the gas completely.
- New start is blocked for T2, which is 2 minutes after ignition and 1 minute after failure while opening main gas.
- Receivers for second thermocouple are marked with a yellow dot. They will not work without the thermocouple connected. Other versions will not work if the thermocouple is connected.
- Second thermocouple function is certified as safety level "B" according to EN 13611.

¹ Standard Handset

² Thermostat & Timer Handset

GV60 - ELECTRONIC OPTIONS

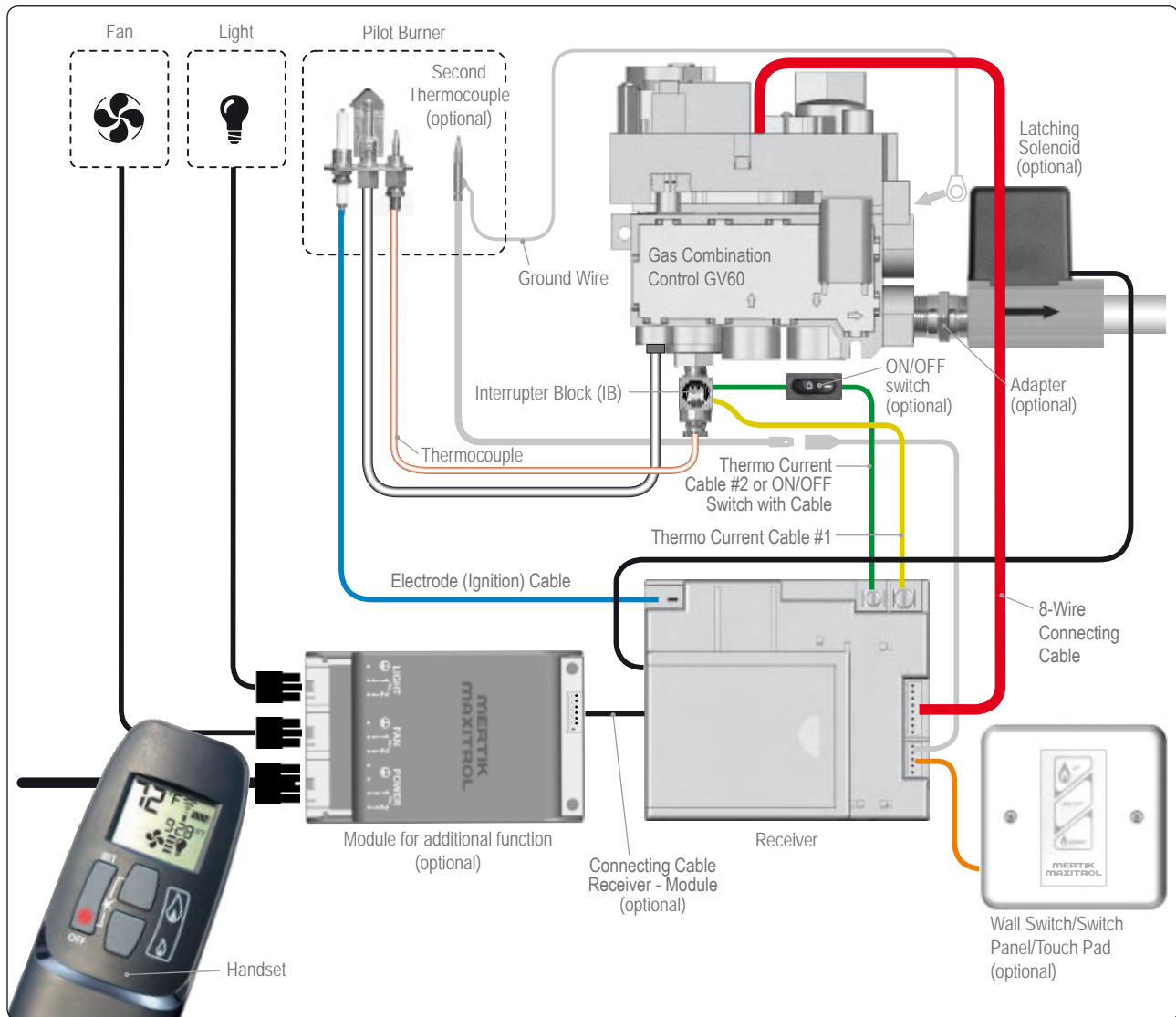

Illustration 19: GV60-Electronic Options

CABLES

G6R-C	G6R-ZKIRF	ON/OFF switch with cable or thermo current cable #2				G60-ZKI..	G6R-SP/G6R-TP	G6R-ZWSN	G6R-CBV		
8-wire connecting cable	Thermo current cable #1	G60-ZSKSF ON/OFF switch with cable (switch in cover)		G60-ZSKLF ON/OFF switch with cable (switch on appliance)		G60-ZKIRSWF Thermo current cable #2	Electrode (ignition) cable	Switch panel with cable/Touch pad with cable	Wall switch with cable	Connecting Cable Receiver - Module	
		IB to switch	Switch to receiver	IB to switch	Switch to receiver						
Length [mm]							ø [mm]	Length [mm]	Length [mm]		
350	350	180	350	350	350	350	4	350, 500, 900, 1200, 1500	1000	500	500
500	800		800	500	500	800	2.45	350, 500, 900, 1200	1500	1500	1000
800	1200		1200	800	800	1200	2.36	350, 500, 900	3000	3000	1500
1200	1800		1800			1800	1.6	350, 500, 900, 1800	8000	8000	
1800							1.3	350, 500, 900			
							2.8x 0.5 mm	350, 500, 900, 1500, 1800			

GV60 - ELECTRONIC OPTIONS - CABLES



GV60 - ACCESSORIES AND REPLACEMENT PARTS (more available on request)









				
Ignition Cable	ON-OFF Switch with Cable	ThermoCurrent Cable	Relay with Cable Exhaust G6R-CL..	Cable for second Thermocouple
				
Pilot Burner	Thermo Current Interrupter	Plug for Cover	Plugs	Inlet/Outlet Adapter for Thread Connection
				
Adjustable and Fixed Orifices	Compression Fittings	Mains Adapter with connections for EU, UK and U.S.		
				
Touch Pad	Wall Switch CE version	Wall Switch CSA version	Switch Panel with Cable	
				
Examples for module for additional function (different module versions for CE/CSA available)	Cable module - receiver	Connection Cable with Battery Holder	Wall Holder	

Illustration 20: GV60 Series - Accessories and Replacement Parts

GV60 - ACCESSORIES AND REPLACEMENT PARTS

GV30 SERIES FOR COMMERCIAL COOKING

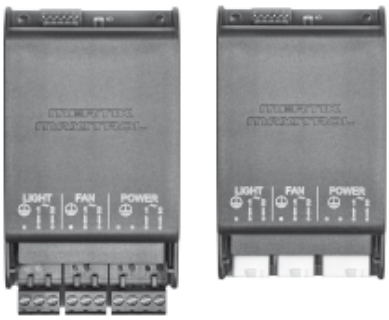
GV30, GV30 max and GV31 gas combination controls were designed for commercial cooking equipment. Different sensors are available for specific applications. The GV Series controls can be equipped with D-stems allowing the customer to use their own knobs, personalizing the appliance front. Also available with ambient temperature compensator.

MAIN VALVE FUNCTION

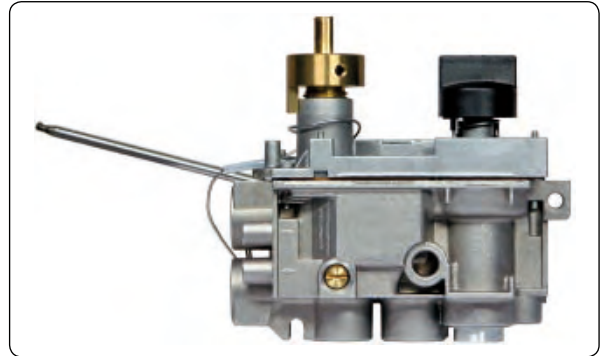
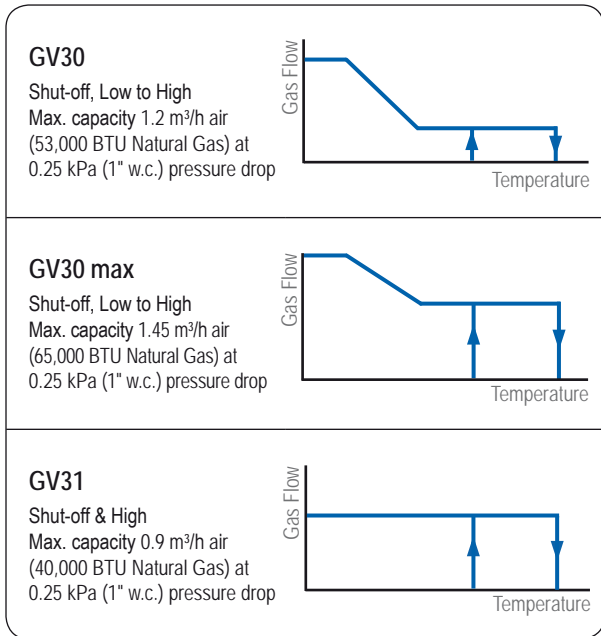

Illustration 21: GV30 Series, Standard

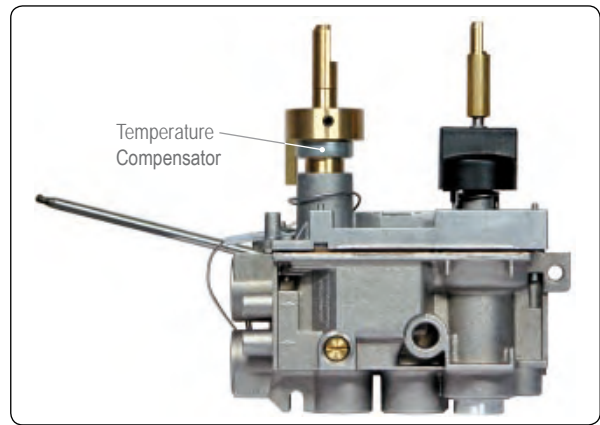

Illustration 22: GV30 Series with temperature compensator

PRESSURE DROP DIAGRAM

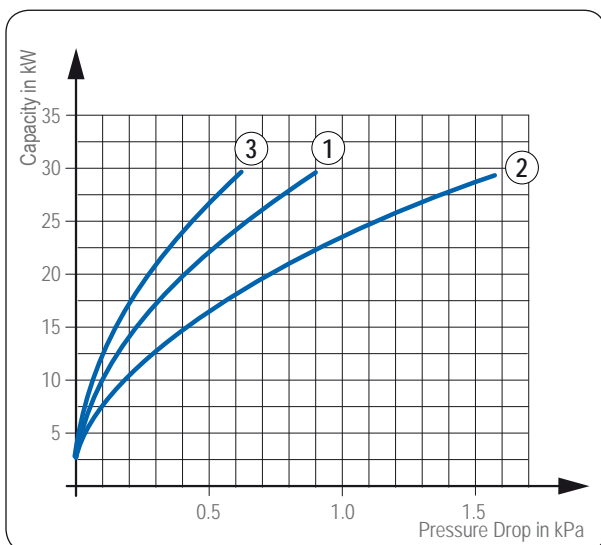

Illustration 23: Pressure Drop Diagram in kPa

① - GV30 / ② - GV31 / ③ - GV30 max

1 kPa = 10 mbar = 4.015" w.c.

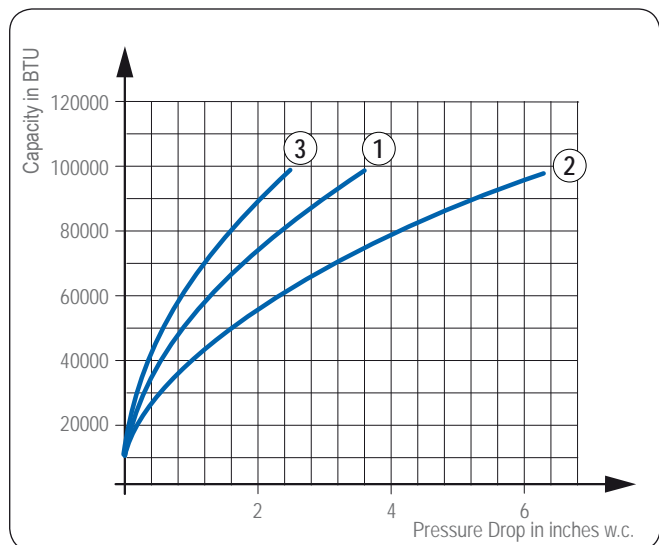

Illustration 24: Pressure Drop Diagram in inches w.c.





GV30 SERIES FOR COMMERCIAL COOKING

WORKING DIAGRAM

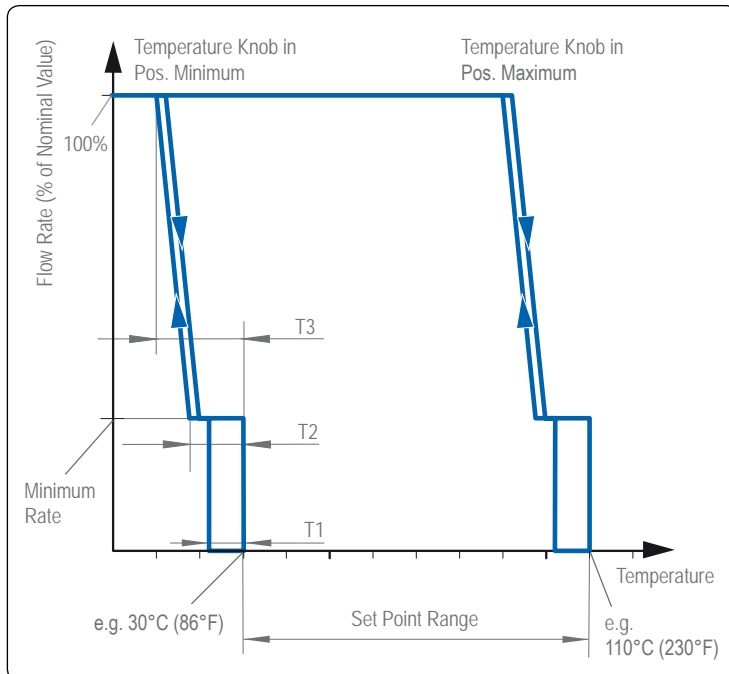

Illustration 25: Working Diagram (Example for set point range 30° to 110°C/86° to 230°F)

Set Point Range	T1 ¹ [K]	T2 [K]	T3 [K]	T _{max} ²
30° to 110°C 86° to 230°F	8	< 13	< 20	180°C 356°F
66° to 260°C 150.8° to 500°F	14	< 22	< 35	350°C 662°F
100° to 340°C 212° to 644°F	17	< 28	< 43	350°C 662°F
110° to 190°C 230° to 374°F	6	< 10	< 15	260°C 500°F

¹ Mean Value

² Maximum Bulb Temperature

SENSORS (other sensors available on request)

Application	Sensor (stainless steel)	Temperature Range °C (°F)	Capillary Length mm (ft)	Sensor Length mm (inch)	Sensor Diameter mm (inch)
Bain Marie		30...110 (86...230)	810 (2.7)	79 (3.1)	6 (0.24)
Griddle Plate		66...260 (150.8...500)	1350 (4.43)	103 (4.06)	4 (0.16)
Oven		100...340 (212...644)	810 (2.7)	86 (3.39)	4 (0.16)
Deep Fryer ³		110...190 (230...374)	810 (2.7)	160 (6.3)	5 (0.20)

Illustration 26: GV30 Series - Sensors

³With or without fitting 1/4 NPT or Rc 1/4" available.



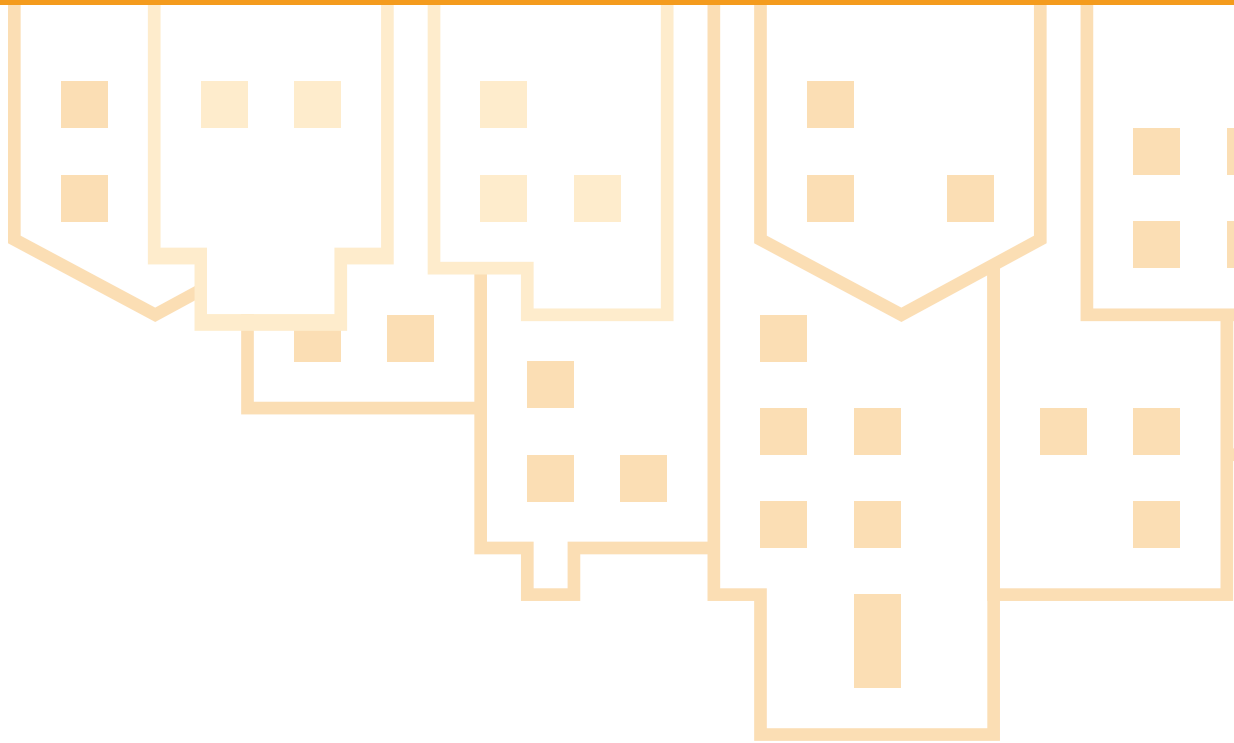

MERTIK MAXITROL®

Exclusive Distributor Europe
for Maxitrol Company

Mertik Maxitrol GmbH & Co. KG
Warnstedter Str. 3
06502 Thale
Germany
Tel: + 49 3947 400-0
Fax: + 49 3947 400-200
www.mertikmaxitrol.com

MAXITROL®

Exclusive Distributor North America
for Mertik Maxitrol

Maxitrol Company, Inc.
23555 Telegraph Rd., PO Box 2230
Southfield, MI 48037-2230
USA
Tel: +1 248-356-1400
Fax: +1 248-356-0829
www.maxitrol.com

GV-CC-EN-07.2010